

Flexo Line

www.atsourcing.fr

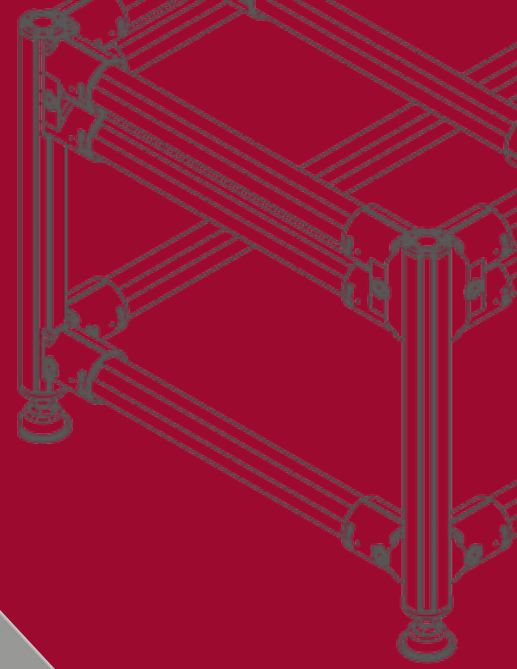

PIPE RACKING SYSTEM

AT SOURCING

ISO 9001/ISO 14001 Certified

MENU

PIPES by

Pages 3 to 10

Technical specifications	4 - 7
Aluminium pipes	8 - 10

JOINTS by

Pages 11 to 44

Metal Joints

Ø28	12 - 18
Assemblies	19 - 25
Rings	25 - 26

Aluminium Joints

Ø28	27 - 33
Ø43	34 - 36
Technical specifications	36 - 40

Aluminium Profiles

41 - 44

ROLLER TRACKS by

Pages 45 to 65

Technical specifications	46 - 47
Roller tracks	48 - 51
Connectors	52
Mounting bracket	53 - 62
Box guide	63 - 64
Accessories	65

CASTERS by

Pages 67 to 72

Casters	67 - 69
Casters holder	70

SQUARE PIPE BASE

Pages 71 to 74

System	71 - 74
--------	---------

ACCESSORIES by

Pages 75 to 107

Plastic accessories

Accessories	76
Separators / Clamps	77

Aluminium accessories

78 - 84

Tiles holder

Metal holder	85
Plastic & Struts	86

Identification

87 - 88

Caps

pipe caps	89 - 91
safety caps	91
roller track caps	92

Inserts

93 - 94

Legs

95 - 96

Screws

97

Security

98

Others

99 - 107



PIPES

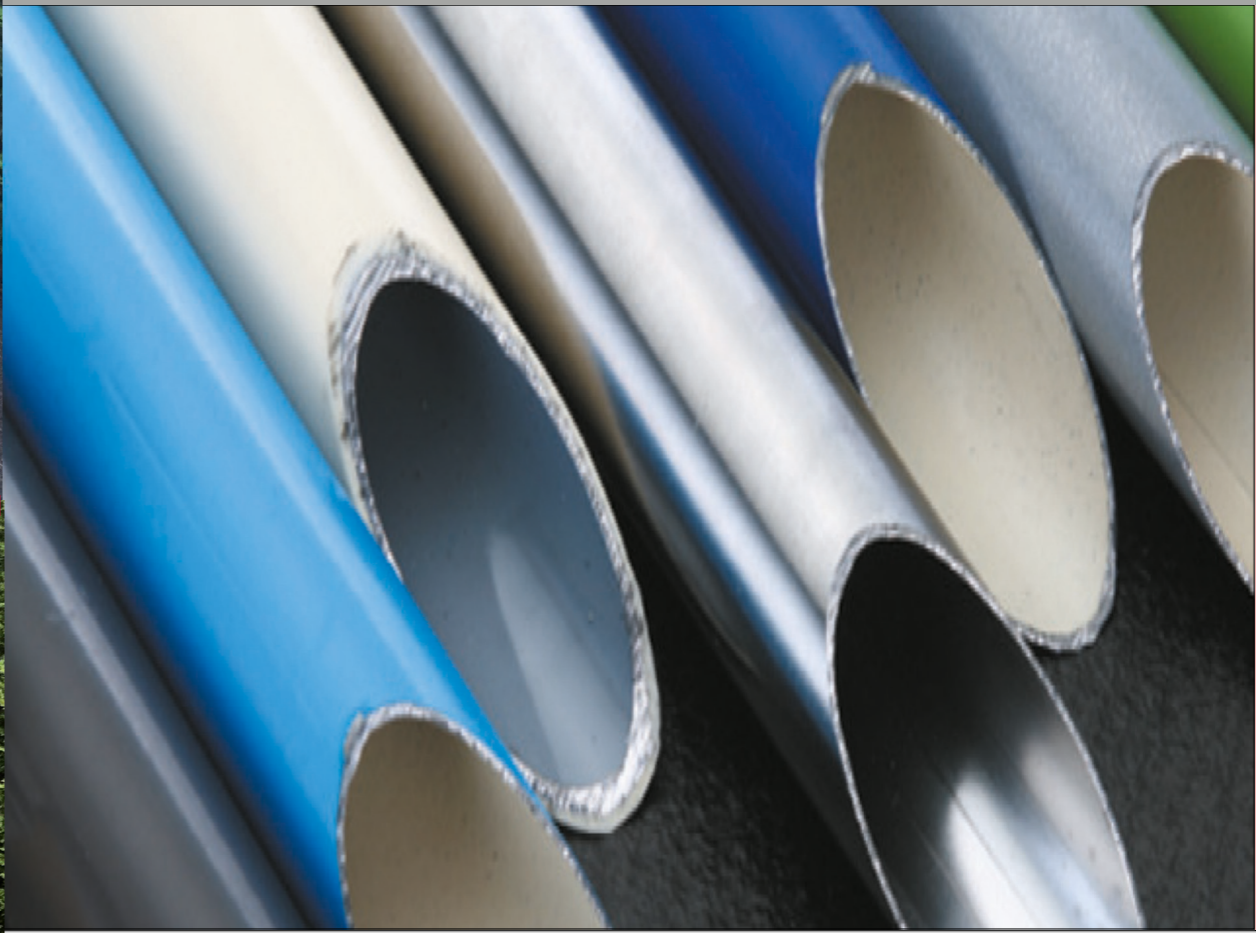

pipes

- DP = Double Coated Pipe
- EP = COATED esd Pipe
- CS = Normal Coated Flat Pipe
- ES = Coated ESD slide Pipe
- CF = NORMAL COATED Flat Pipe
- EF = Coated ESD Stripe pipe
- CL = Coated Black stripe Pipe
- FS = Full Slide Pipe
- LS = L - Slide Pipe
- SP = Spiral Pipe
- S = STS Pipe

DP28 **07** **X**
exemple : case of coated pipe Ivory Ø28 x t1.0 is DP2810-i





Thickness

- 07 = t 0.7
- 09 = t 0.9
- 10 = t 1.0
- 20 = t 2.0





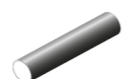





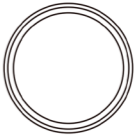
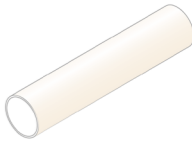
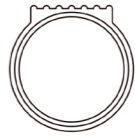
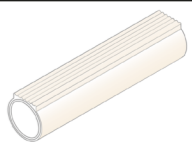

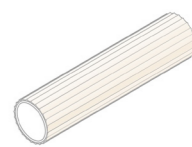
Color Code

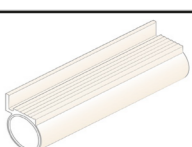
- I = Ivory
- N = Green
- U = Blue
- S = Sky Blue
- K = Dark Blue
- G = Gray
- M = Metallic gray
- Y = Dark gray
- B = Black
- L = Black tripe ESD Ivory
- W = white
- R = Red
- O = Orange
- A = Brown
- RG = Rock Gray
- YE = Yellow
- P = Pink

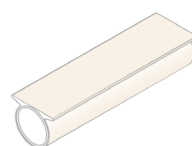
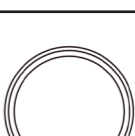
COLOR TABLE

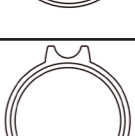
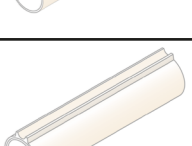
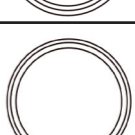
CLASSIFICATION STANDARD COLOR	Standard Length : 4000	Coated Pipe		
		Ø 28 X T1.0	Ø 28 X T2.0	
		Ivory		✓
Green		✓	✓	
Blue		✓	✓	
Sky Blue		✓	✓	
Dark Blue		✓	✓	
Gray		✓	✓	
Rock Gray		✓	✓	
Dark Gray		✓	✓	
Black		✓	✓	
White		✓	✓	
Red		✓	✓	
ESD Pipe 10 ³ Ω~10 ⁶ Ω	Orange		✓	✓
	Yellow		✓	✓
	Pink		✓	✓

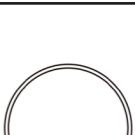
NUMBERING SYSTEM

Classification	Item	Part No		Thickness	Weight (g) / M	Type		
		Normal	ESD					
Coated Pipe	D-Coated Pipe	DP2810-X	EP2810-X	Ø28 x T1.0	700			
		DP2820-X	EP2820-X	Ø28 x T2.0	1.130			
		DP3210-X	-	Ø32 x T1.0	810			
	Slide Pipe	CS2810-X	ES2810-X	Ø28 x T1.0	757			
	Full Slide Pipe	FS2807-X	FS2807-E	Ø28 x T0.7	505			
		FS2809-X	FS2809-E	Ø28 x T0.9	630			
	L. Slide Pipe	LS2810-X	LS2810-E	Ø28 x T1.0	500			
	Flat Pipe	CF2807-X	EF2807-X	Ø28 x T0.7	505			
		CF2810-X	EF2810-X	Ø28 x T1.0	690			
	Black Stripe Pipe	—	CL2807-X	Ø28 x T0.7	505			
		—	CL2810-X	Ø28 x T1.0	690			
	Tube W	RC2809 (Roller Conveyor)		Ø28 x T0.9	630			
	Spiral Pipe	SP2809		Ø28 x T0.9	630			
	STS Pipe	Inox	S2807-PF		Ø28 x T0.7	448		
			S2812 - PF S2812-201 (inox non magnétique)		Ø28 x T1.2	760		

PIPE BENDING STRENGTH

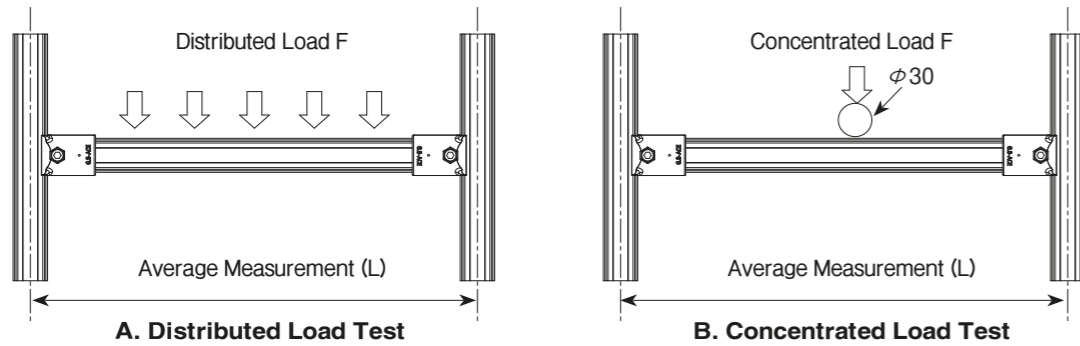

MODEL	TYPE	A. Distributed Load (kgf)			B. Concentrated Load (kgf)			
		L=270mm	L=900mm	L=1500mm	L=270mm	L=900mm	L=1500mm	
AP2812SP		370	120	50	280	90	40	
AP2820SP		X	370	120	50	280	90	40
		Y	500	150	70	380	110	45
AP2829SP		520	160	80	400	120	50	
AR2812SP		300	130	60	240	90	40	
AR2829SP		470	170	70	380	130	50	
AT2829SP		570	140	100	400	100	60	
AFS2812SA		280	130	60	190	90	40	
ATF2812SP		380	140	60	290	100	50	
ALF2812SP		360	140	60	270	100	50	
AD2812SP		X	520	400	220	380	260	100
		Y	870	250	130	620	160	60
AD2829SP		X	680	550	310	500	360	150
		Y	1100	410	220	810	230	100

THE ADVANTAGES OF STAINLESS PIPE

- 1. Environmental**
- Stainless pipe which is 100% recyclable
- 2. High Strength & Durability**
- Surface resistant to light abrasion or contact with metal tools
- 3. High Oil & Chemical Resistance**
- High resistance to oil, solvents, bleaches, etc.
- 4. Non-Flammable**
- Inherently non-flammable.
- 5. Conductive**
- Inherently conductive

STS PIPE VS. COATED PIPE BENDING STRENGTH

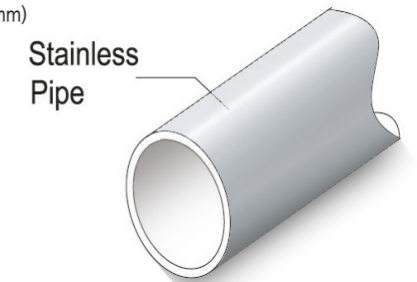
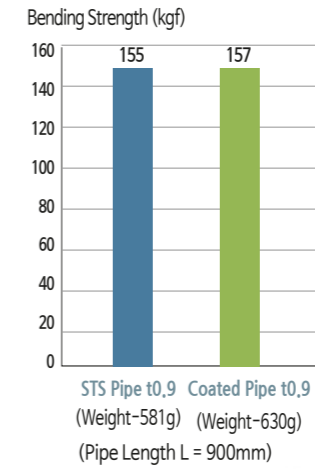

ALUMINIUM PIPES Ø 43

AP4319SP Regular Duty Pipe

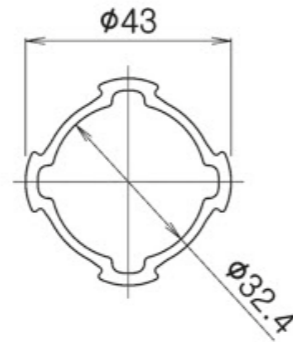
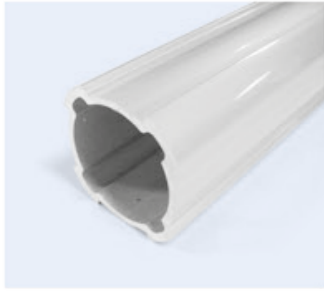

- Weight: 0.735kg/m, External Diameter Ø43

ALUMINIUM PIPES Ø 28

AP2812SP Regular Duty Pipe

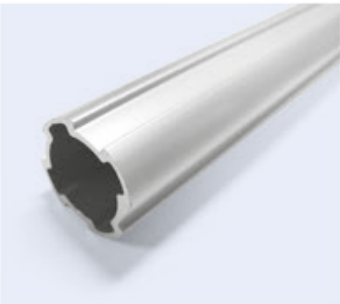

- Weight: 0.378kg/m, External Diameter Ø28
- ※ Please refer to the technical data on the page 85

AP2829SP Heavy Duty Pipe

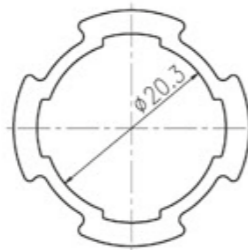
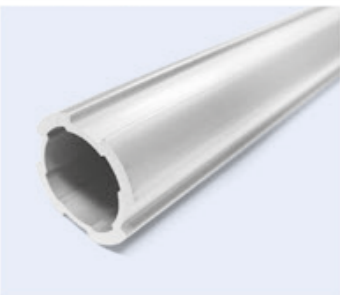

- Weight: 0.479kg/m, External Diameter Ø28
- ※ Please refer to the technical data on the page 85

AP2820SP Light Heavy Duty Pipe

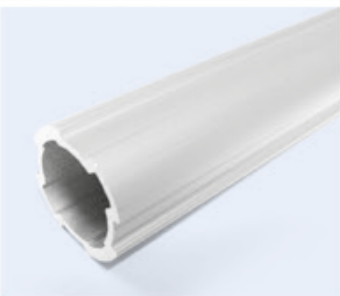

- Weight: 0.440kg/m, External Diameter Ø28
- ※ Please refer to the technical data on the page 85



AR2812SP Round Pipe(Regular Duty)

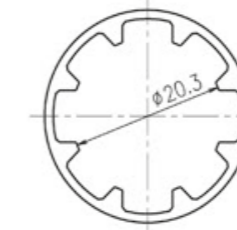
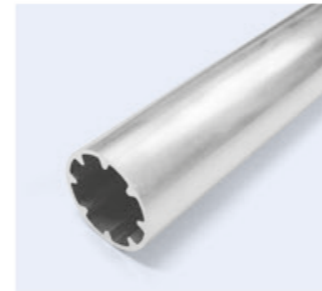

- Weight: 0.377kg/m, External Diameter Ø28
- ※ Please refer to the technical data on the page 85

AR2829SP Round Pipe(Heavy Duty)

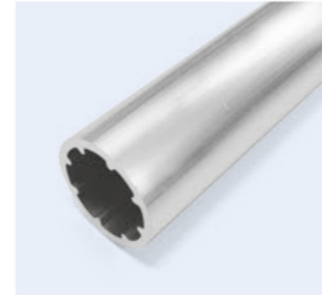

- Weight: 0.495kg/m, External Diameter Ø28
- ※ Please refer to the technical data on the page 85



AD2812SP Double Pipe (Heavy Duty)

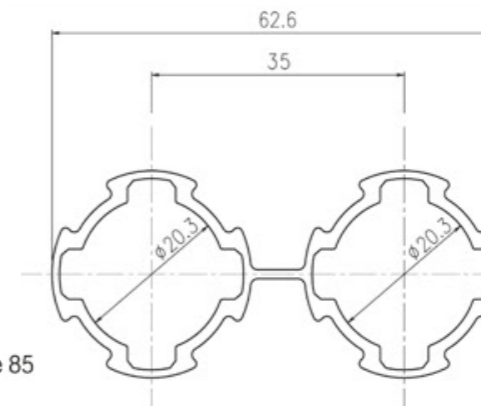
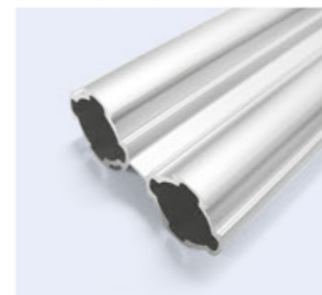

- Weight: 0.784kg/m, External Diameter Ø28
- ※ Please refer to the technical data on the page 85

AD2829SP Double Pipe (Extra Heavy Duty)

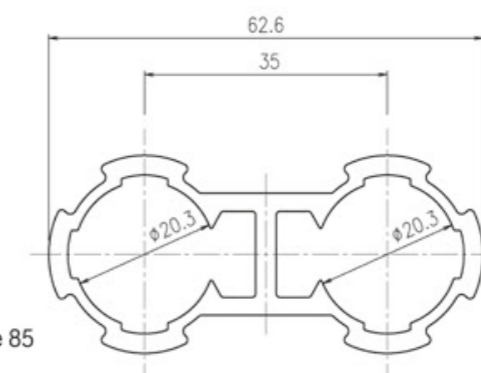
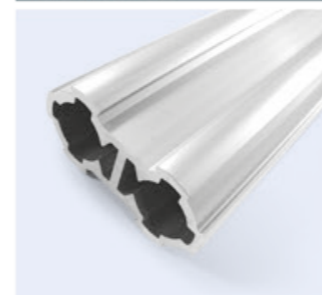

- Weight: 1.146kg/m, External Diameter Ø28
- ※ Please refer to the technical data on the page 85

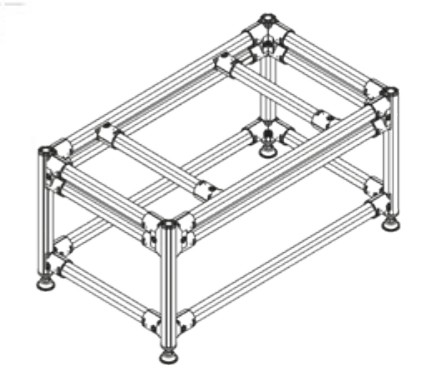

AT2829SP T Slot Pipe

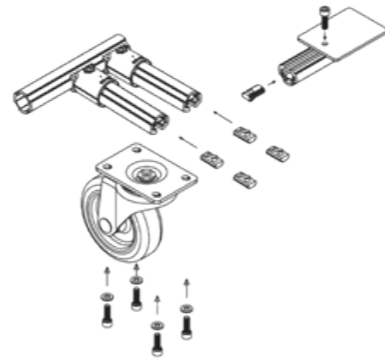
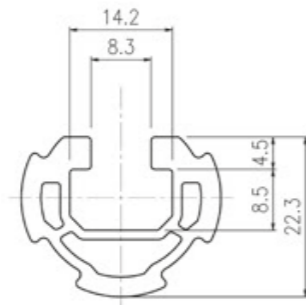
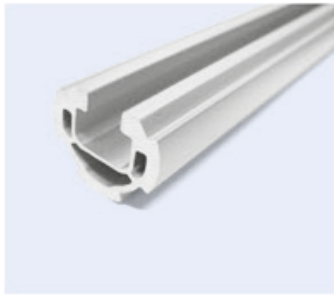

- Weight: 0.605kg/m, External Diameter Ø28
- ※ Spring Nuts (shown in Page 85) can be used in the slot to attach various items.
- ※ Slot will facilitate the linear movement of attached item

ATF2812SP T-Flat Pipe

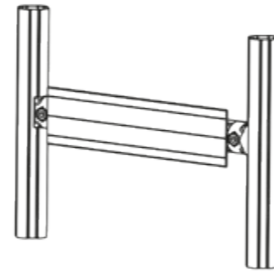
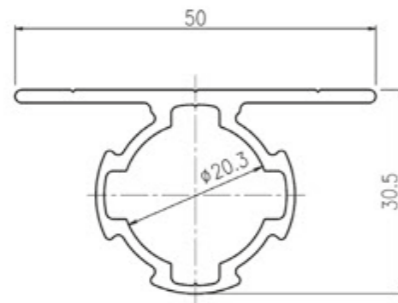
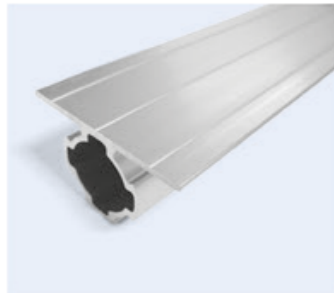

- Weight : 0.681kg/m, External Diameter Ø28
- ※ Please refer to the technical data on the page 85

ALF2812SP L-Flat Pipe

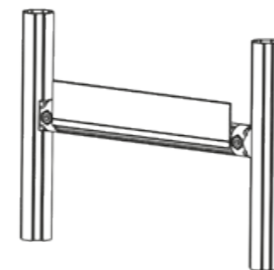
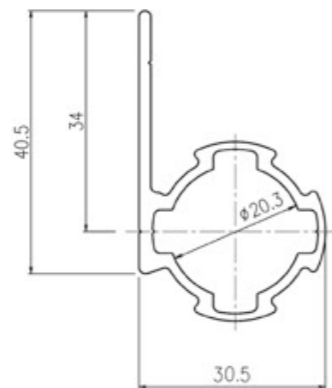
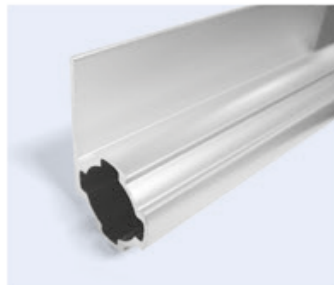

- Weight : 0.638kg/m, External Diameter Ø28
- ※ Please refer to the technical data on the page 85

AFS2812SA Full Slide Pipe

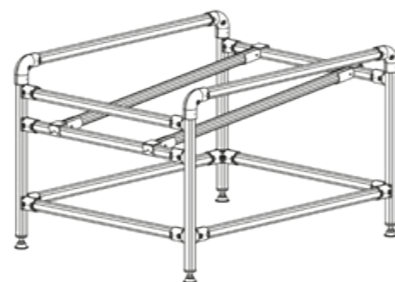
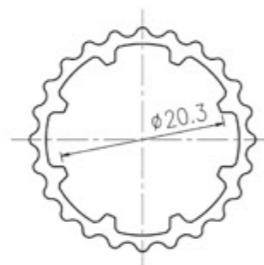
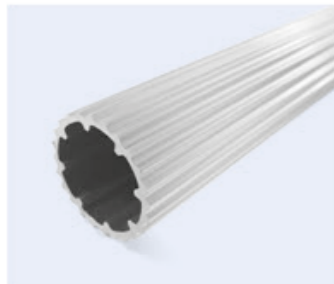

- Weight : 0.377kg/m, External Diameter Ø28
- ※ Sliding Pipe will facilitate the linear movement.

METAL JOINTS

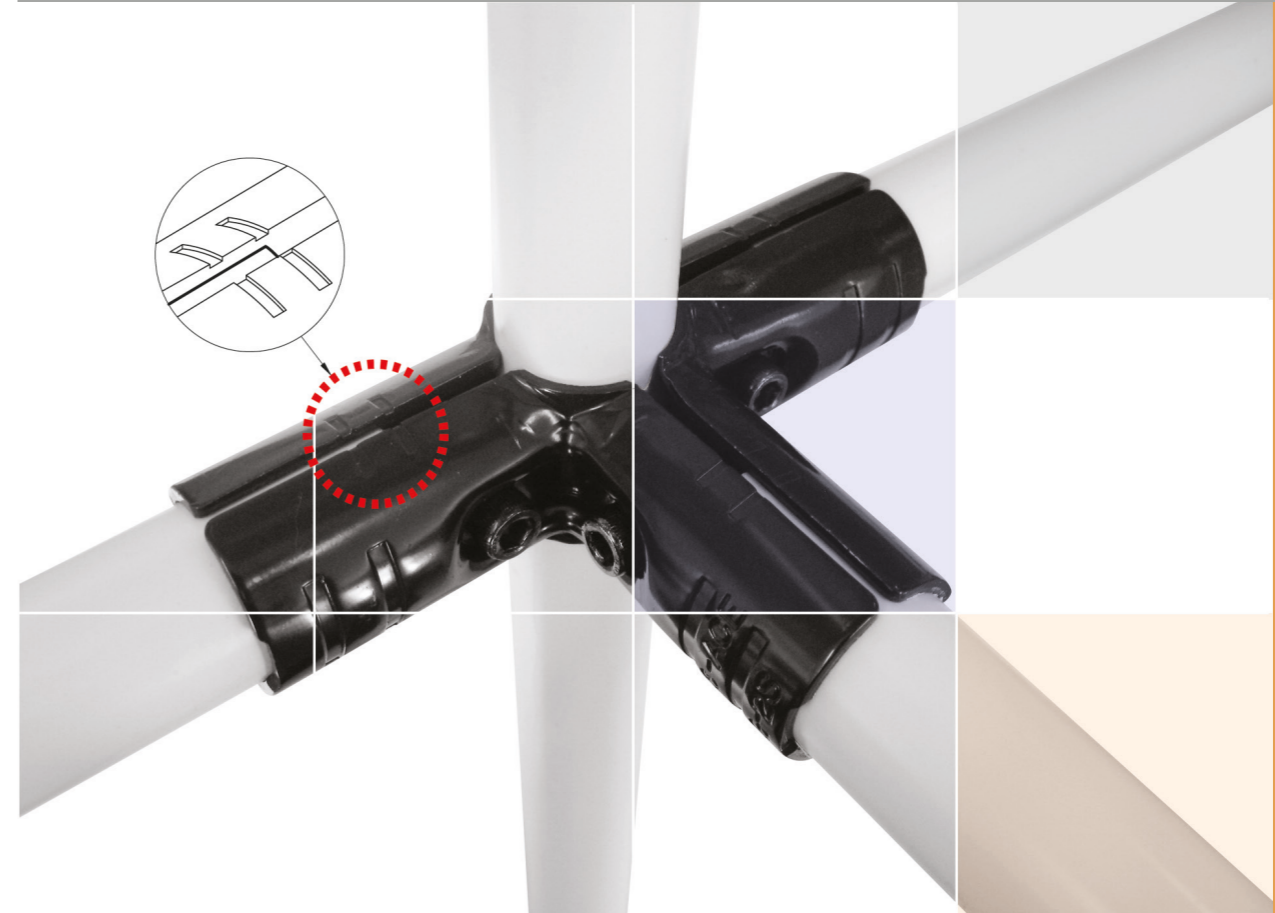

- COLORS**
- Black
 - White
 - Nickel

S-Series Joint

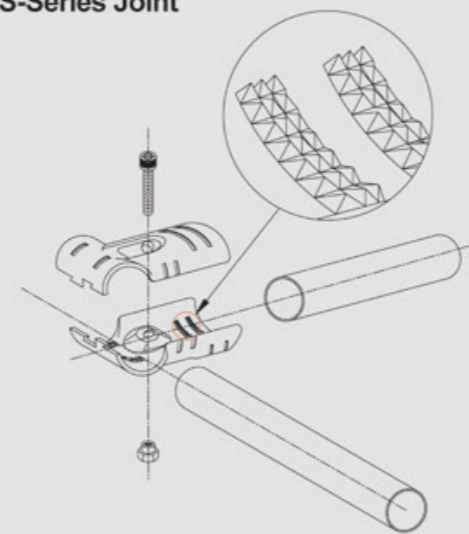

METAL JOINTS - SERIES FEATURES

- ✦ Developed and patented design for 28 stainless steel pipes.
- ✦ Excellent grip characteristics achieved by introducing series of protruded pyramids in contact with stainless steel pipes.
- ✦ When used with coated pipes, grip is enhanced by 30 %

SURFACE TREATMENT & CODE NUMBER

Code	Surface treatment	Remarks
BK	Black Coating	Non Chrome
WZ	Zinc Plating (white)	Cro3
Ni	Nickel Plating	Non Chrome

Unit : mm

Unit : mm

Unit : mm

G-1S

- Weight : 0.068kg
- Q'ty/Box : 240pcs

G-1BS

- Weight : 0.061kg
- Q'ty/Box : 240pcs

G-7AS

- Weight : 0.044kg
- Q'ty/Box : 300pcs

G-7BS

- Weight : 0.052kg
- Q'ty/Box : 300pcs

G-2S

- Weight : 0.095kg
- Q'ty/Box : 150pcs

G-3S

- Weight : 0.120kg
- Q'ty/Box : 70pcs

G-7CS

Utility Model Patent

- Weight : 0.062kg
- Q'ty/Box : 210pcs

G-8S

Design Patent No. 0256329

- Weight : 0.049kg
- Q'ty/Box : 300pcs

G-4S

- Weight : 0.105kg
- Q'ty/Box : 180pcs

G-6S

- Weight : 0.048kg
- Q'ty/Box : 180pcs

G-9S

- Weight : 0.120kg
- Q'ty/Box : 100pcs

G-12S

- Weight : 0.060kg
- Q'ty/Box : 210pcs

G-6BS

- Weight : 0.042kg
- Q'ty/Box : 240pcs

G-6B-33

- Weight : 0.046kg
- Q'ty/Box : 180pcs

G-13AS

- Weight : 0.063kg
- Q'ty/Box : 160pcs

G-13BS

- Weight : 0.062kg
- Q'ty/Box : 160pcs



Unit : mm

Unit : mm

G-14S

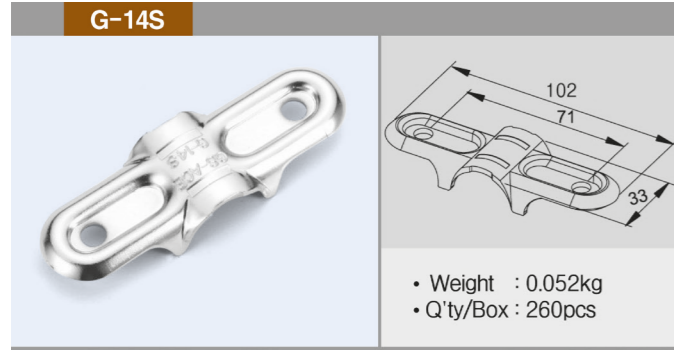

- Weight : 0.052kg
- Q'ty/Box : 260pcs

G - 15AC Back Stopper Bracket

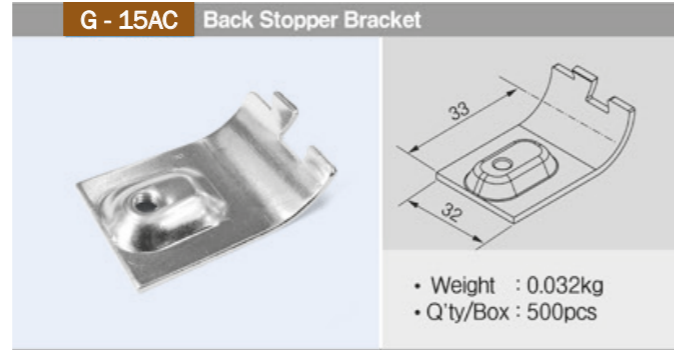

- Weight : 0.032kg
- Q'ty/Box : 500pcs

G-18S

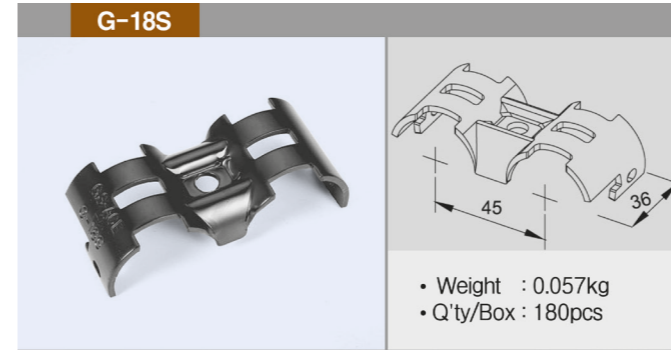

- Weight : 0.057kg
- Q'ty/Box : 180pcs

G-20S

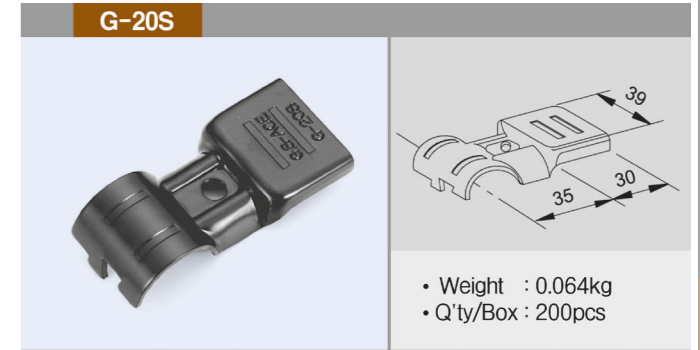

- Weight : 0.064kg
- Q'ty/Box : 200pcs

G-15AH

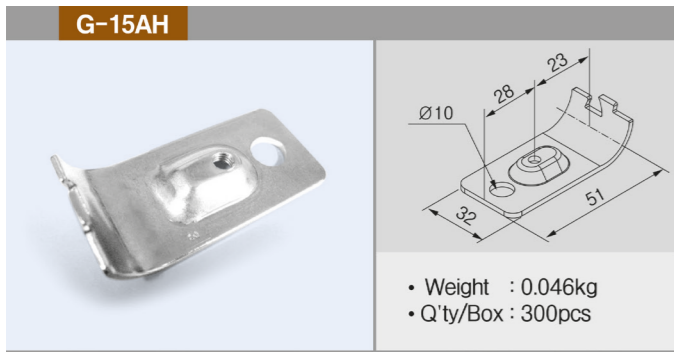

- Weight : 0.046kg
- Q'ty/Box : 300pcs



G-22S

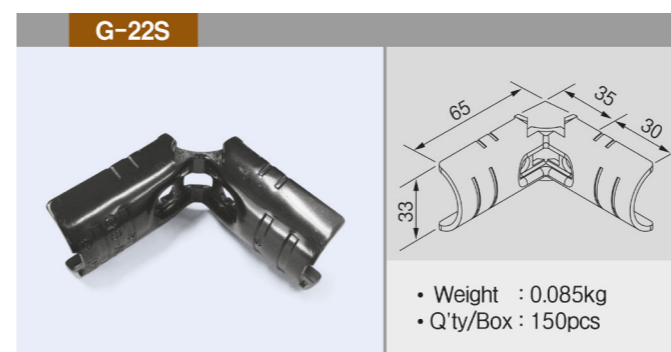

- Weight : 0.085kg
- Q'ty/Box : 150pcs

G-24S

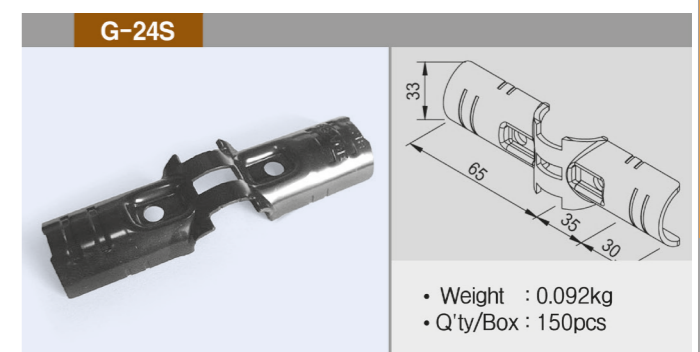

- Weight : 0.092kg
- Q'ty/Box : 150pcs

G-15AS

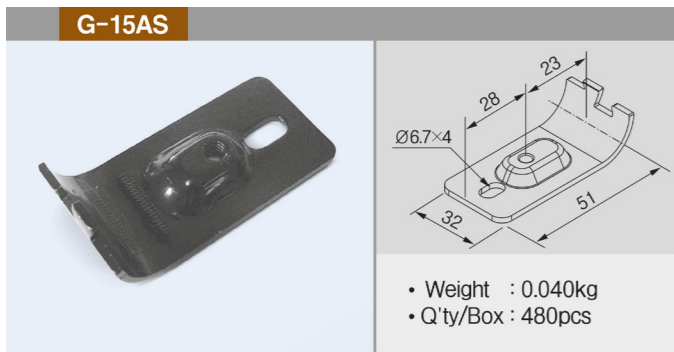

- Weight : 0.040kg
- Q'ty/Box : 480pcs

G-15BS

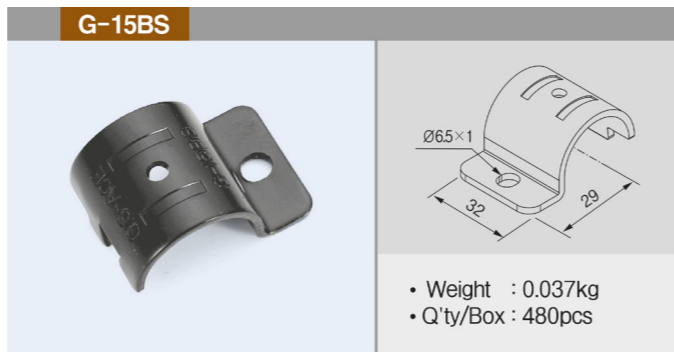

- Weight : 0.037kg
- Q'ty/Box : 480pcs

G-25AS



- Weight : 0.050kg
- Q'ty/Box : 360pcs

G-25BS

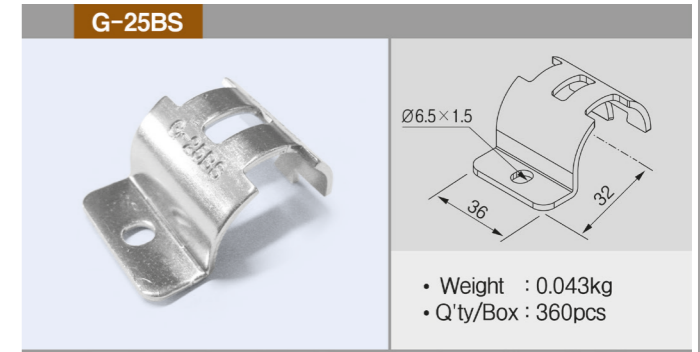

- Weight : 0.043kg
- Q'ty/Box : 360pcs

G-15D

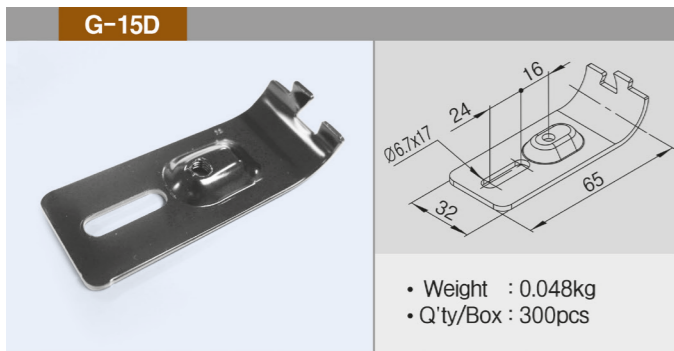

- Weight : 0.048kg
- Q'ty/Box : 300pcs

G-16S

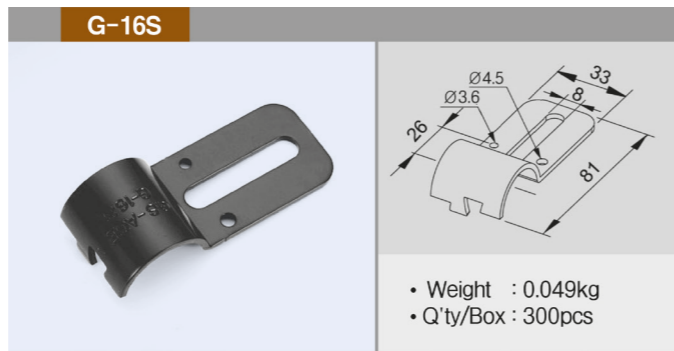

- Weight : 0.049kg
- Q'ty/Box : 300pcs

G-25C

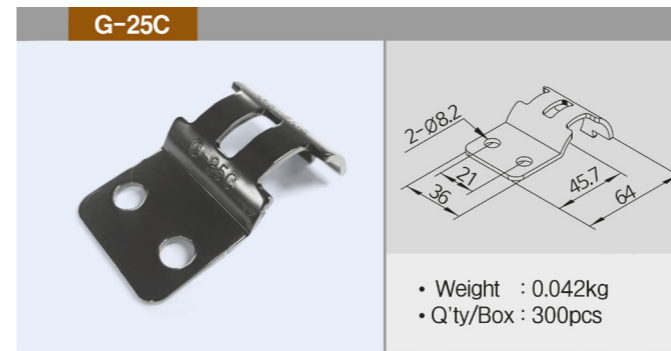

- Weight : 0.042kg
- Q'ty/Box : 300pcs

G-28

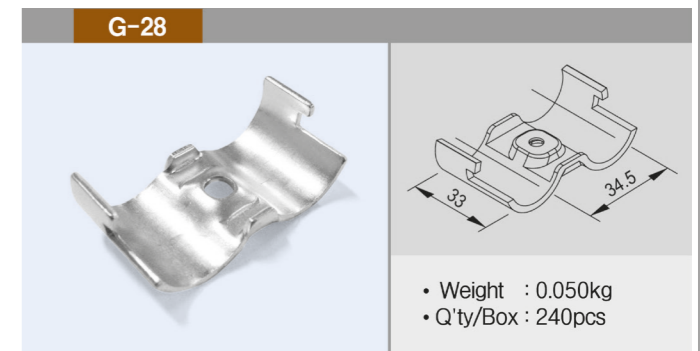

- Weight : 0.050kg
- Q'ty/Box : 240pcs

G-17S

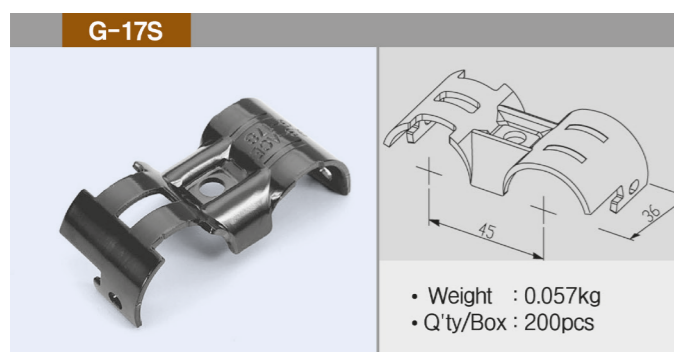

- Weight : 0.057kg
- Q'ty/Box : 200pcs

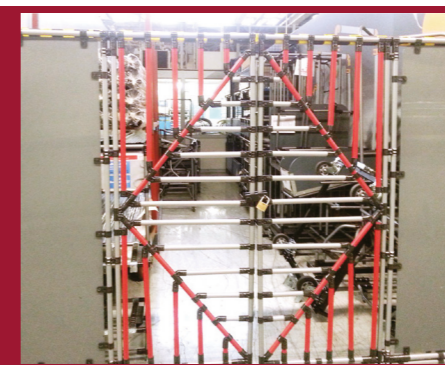

Unit : mm

Unit : mm

G-30S

- Weight : 0.060kg
- Q'ty/Box : 240pcs

G-34S

- Weight : 0.105kg
- Q'ty/Box : 180pcs

G-60S

- Weight : 0.076kg
- Q'ty/Box : 200pcs

G-65S For Ø5

- Weight : 0.038kg
- Q'ty/Box : 480pcs

G-35AS

- Weight : 0.080kg
- Q'ty/Box : 240pcs

G-35BS

- Weight : 0.075kg
- Q'ty/Box : 240pcs

G-65S-10 For Ø10

- Weight : 0.0380kg
- Q'ty/Box : 480pcs

G-66 Material : Aluminium

- Weight : 0.042kg
- Q'ty/Box : 160pcs

G-38S

- Weight : 0.057kg
- Q'ty/Box : 300pcs

G-44
Utility Model Patent
Design Patent

- Weight : 0.070kg
- Q'ty/Box : 270pcs

G-90S
Utility Model Patent

- Weight : 0.096kg
- Q'ty/Box : 100pcs

G-101

- Weight : 0.074kg
- Q'ty/Box : 180pcs

* For Ø28.6

G-45S

- Weight : 0.071kg
- Q'ty/Box : 200pcs

G-54S

- Weight : 0.099kg
- Q'ty/Box : 120pcs

G-102

- Weight : 0.074kg
- Q'ty/Box : 200pcs

* For Ø28.6

G-103

- Weight : 0.07kg
- Q'ty/Box : 240pcs

* For connection at the top of joint



Unit : mm

Unit : mm

G-104

- Weight : 0.070kg
- Q'ty/Box : 240pcs

G-105

- Weight : 0.080kg
- Q'ty/Box : 200pcs

GA-1BS

- G-1BS : 2pcs
- M0625/TN06 : 1set

GA-1S

- G-1S : 2pcs
- M0625/TN06 : 1set

G-106

- Weight : 0.078kg
- Q'ty/Box : 200pcs

G-110S

Design Patent

- Weight : 0.103kg
- Q'ty/Box : 100pcs

GA-2S

- G-2S : 1pcs G-3S : 1pcs
- M0625/TN06 : 2set

GA-3S

- G-2S : 2pcs G-4S : 1pcs
- M0625/TN06 : 3set



GA-4S

- G-4S : 2pcs
- M0625/TN06 : 2set

GA-5S

- G-2S : 4pcs
- M0625/TN06 : 4set

GA-6S

- G-6S : 2pcs
- M0625/TN06 : 1set

GA-6BS

- G-6BS : 2pcs
- M0625/TN06 : 1set

GA-6B-33

- G-6B-33 : 2pcs
- M0625/TN06 : 1set

GA-7S

- G-7AS : 2pcs G-7BS : 2pcs
- M0625/TN06 : 2set

Unit : mm

GA-8S

- G-8S : 2pcs
- M0625/TN06 : 1set

GA-9S

- G-9S : 2pcs
- M0625/TN06 : 1set

GA-16S

- G-16S : 2pcs
- PW8 * 25 : 2pcs

GA-17S

* For one-side fixing

- G-17S : 2pcs GAP-12:1pcs
- M0625/TN06 : 1set

GA-13S

- G-13AS:1pcs G-13BS:1pcs
- M0625/TN06 : 1set

GA-14S

- G-14S:2pcs G7BS:4pcs
- M0625/TN06 : 4set

GA-18S

- G-18S : 2pcs GAP-12:2pcs
- M0625/TN06 : 1set

GA-20S

- G-20S : 1pcs G-1S:1pcs
- M0625/TN06 : 1set

Example for GA-15S

GA-21A

Registration patent

- G-21A : 2pcs
- HM0620/TN06 : 1set

GA-24S

- G-24S : 2pcs GAP-12:1pcs
- M0625/TN06 : 2set

GA-25C

- G-25C:2pcs GAP-12:1pcs
- M0825/N08 : 2set

GA-25S

- G-25AS:1pcs G-25BS:1pcs
- GAP-12:1pcs M0610:1pcs

GA-15D

- G-15D : 1pcs G-15BS: 1pcs
- M0610 : 1pcs

GA-15S

- G-15AS:1pcs G-15BS:1pcs
- M0610 : 1pcs

GA-27S

Utility Model Patent

- G-7CS : 2pcs G-7BS : 2pcs
- M0625/TN06 : 3set

GA-28

- G-28 : 2pcs
- M0625/TN06 : 1set

Unit : mm

Unit : mm

GA-30S

- G-30S : 2pcs
- M0625/TN06 : 1set

GA-34S

- G-34S : 2pcs
- M0625/TN06 : 2set

GA-65S For $\varnothing 5$

- G-65S : 2pcs
- M0610/TN06 : 1set

GA-65S-10 For $\varnothing 10$

- G-65S-10 : 2pcs
- M0610/TN06 : 1set

Example for GA-34S

GA-35S

- G-35AS : 1pcs G-35BS : 1pcs
- GAP-56 : 1pcs M0610 : 1pcs

GA-66 Material : Aluminium

- G-66 : 2pcs
- M0625/TN06 : 1set

GA-90S
Utility Model Patent

- G-90S : 2pcs
- M0625/TN06 : 1set

GA-38S

- G-38S : 2pcs
- M0625/TN06 : 1set

GA-44
Utility Model Patent
Design Patent

- G-44 : 2pcs
- M0625/TN06 : 1set

GA-101

- G-101 : 2pcs
- M0625/TN06 : 1set

GA-102

- G-102 : 2pcs
- M0625/TN06 : 1set

GA-45S

- G-45S : 2pcs
- M0625 / TN06 | 1set

GA-54S

- G-54S : 1pcs G-4S : 1pcs
- M0625/TN06 : 2set

GA-103

- G-103 : 2pcs
- M0625/TN06 : 1set

GA-104

- G-104 : 2pcs
- M0625/TN06 : 1set

GA-55S

- G-22S : 4pcs GAP-12 : 1pcs
- M0625/TN06 : 4set

GA-60S

- G-60S : 2pcs
- M0625/TN06 : 1set

GA-105

- G-105 : 2pcs
- M0630/TN06 : 1set

GA-106

- G-106 : 2pcs
- M0625/TN06 : 1set

Unit : mm

GA-110S

Design Patent

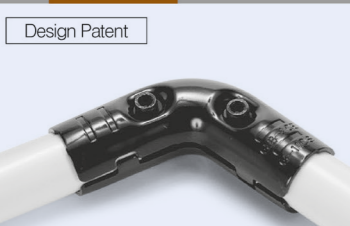
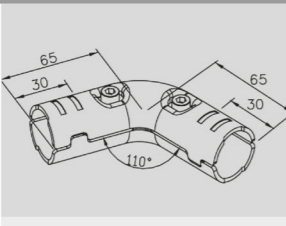
- G-110S : 2pcs
- M0625/TN06 : 2set

GA-135S

- G-135S : 2pcs
- M0625/TN06 : 2Set

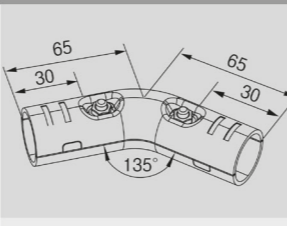
GA-160S

Design Patent



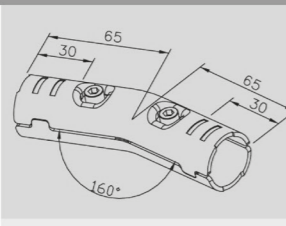

- G-160S : 2pcs
- M0625/TN06 : 2set

Example for GA-110S, GA-160S

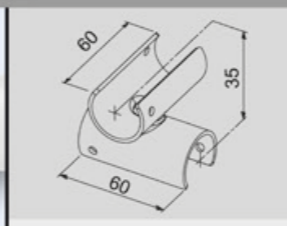

PS - A Rotating Cross Joint

- Weight : 0.128kg
- Q'ty/Box : 96pcs

PS - B Rotating Cross Joint

- Weight : 0.104kg
- Q'ty/Box : 96pcs

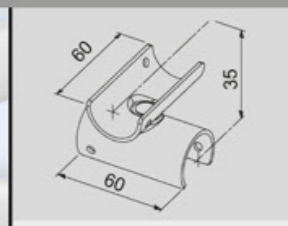
PS - C Rotating Cross Joint

- Weight : 0.105kg
- Q'ty/Box : 70pcs

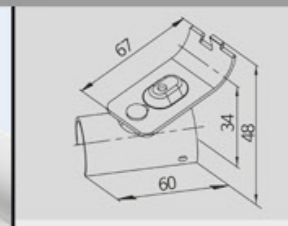

GAP - 12 Sleeve (For GA-12S/17S/18S/24S/25S)

- Weight : 0.007kg
- Q'ty/Box : 600pcs

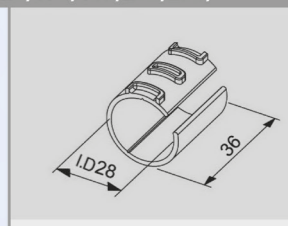
GAP - 44 Sleeve (For GA-12S/17S/18S/24S/25S)

- Weight : 0.012kg
- Q'ty/Box : 200pcs

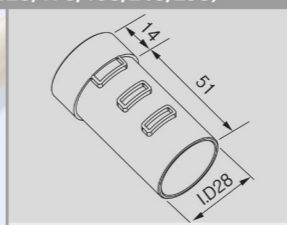
GAP - 56 Sleeve (For GA-35S)





- Weight : 0.010kg
- Q'ty/Box : 300pcs

Unit : mm

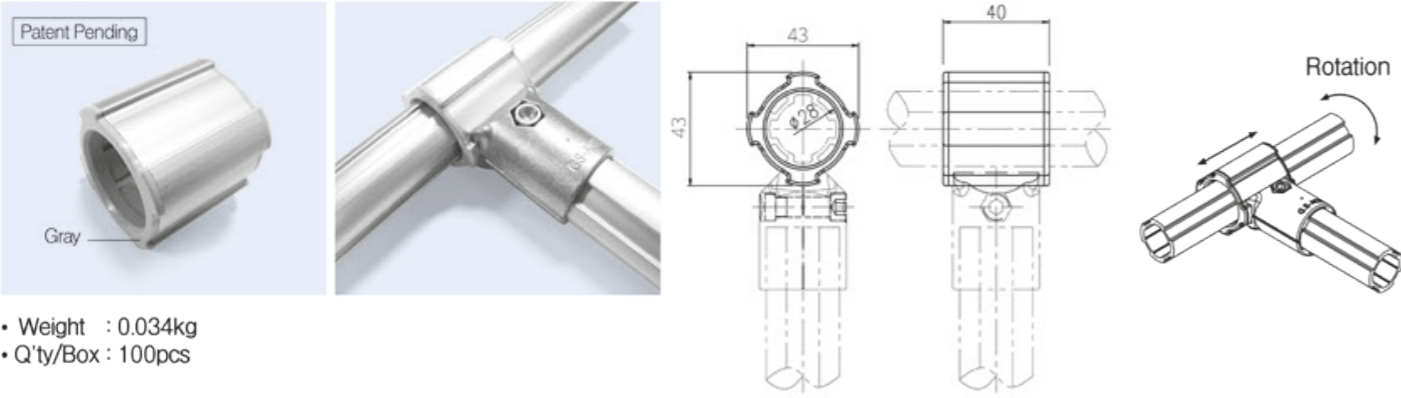
AH-540 Aluminum Sleeve (Short Type)

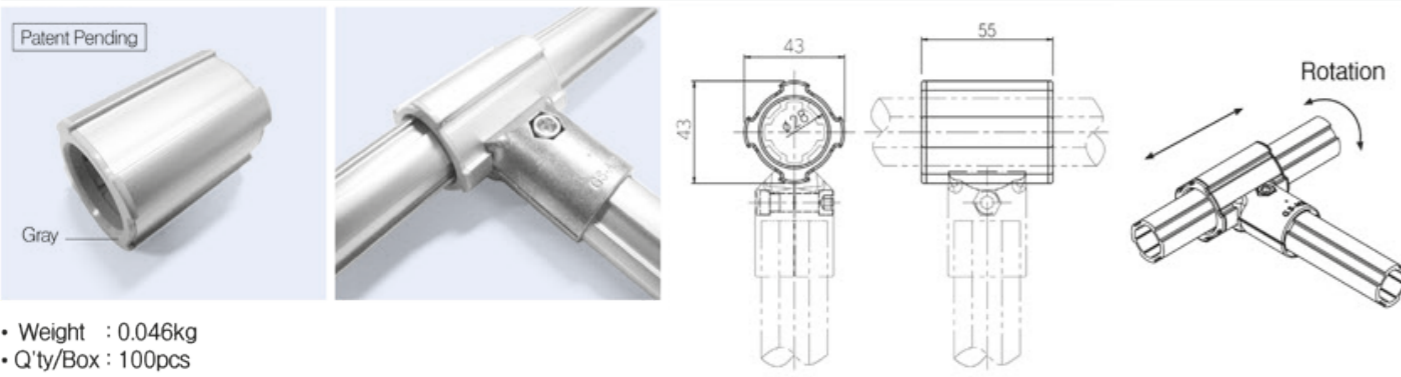

AH-555 Aluminum Sleeve (Long Type)



AH-640 Aluminum Sleeve (Short Type)

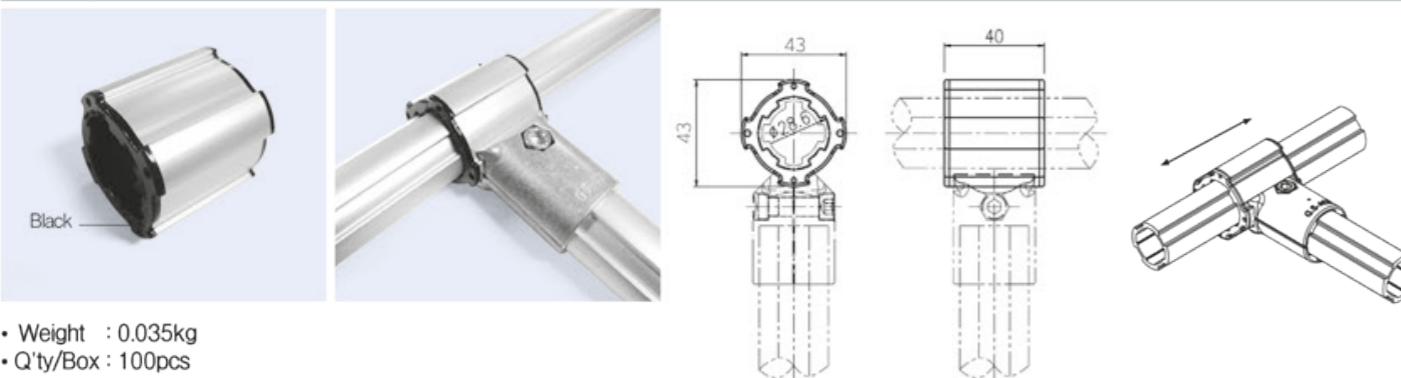

AH-655 Aluminum Sleeve (Long Type)

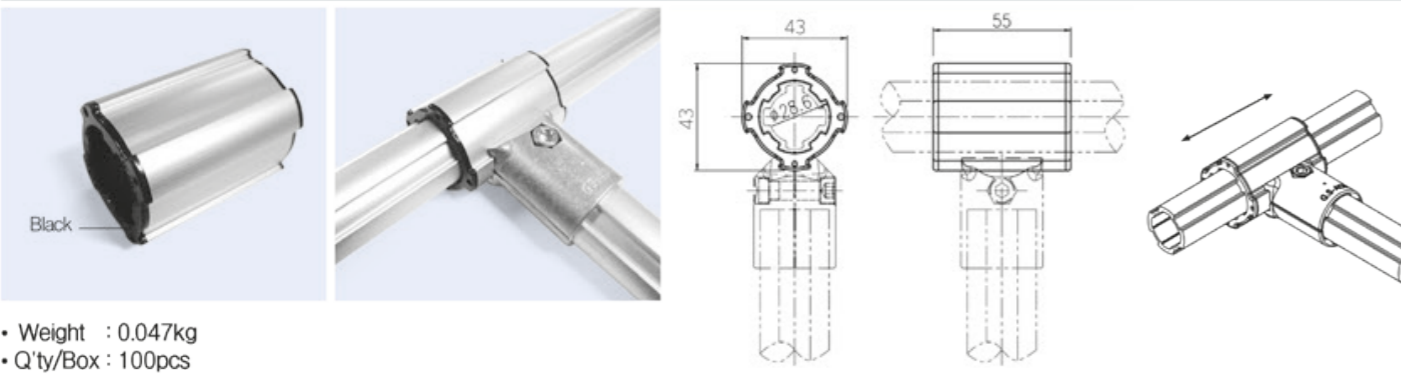

ALUMINIUM JOINTS

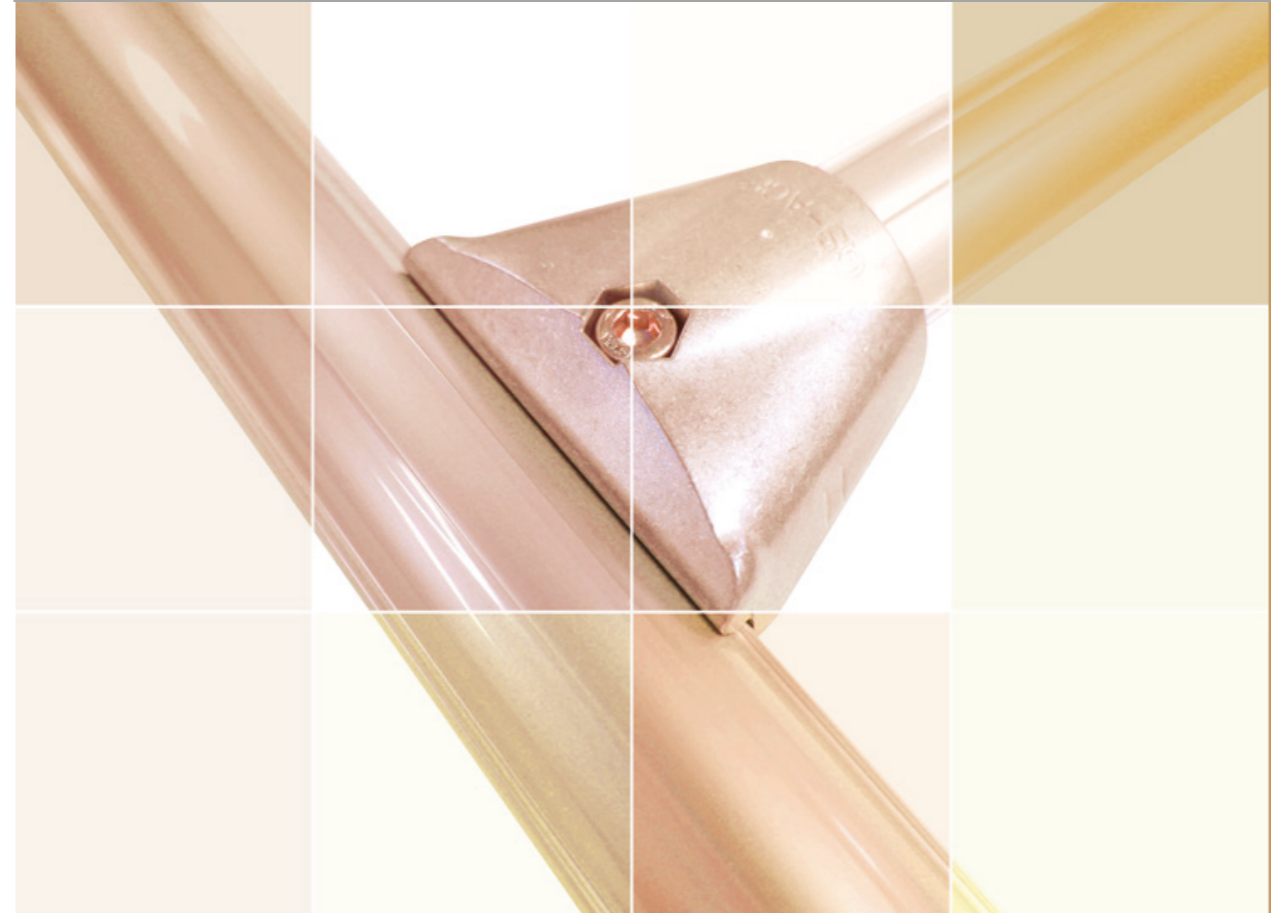

JOINTS

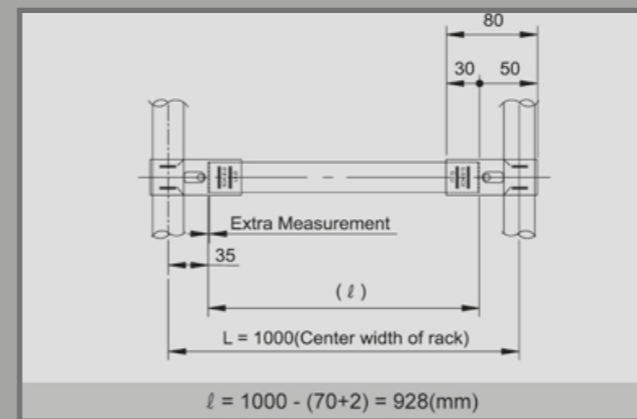

Case of $\varnothing 28 \text{ mm}$

1000 mm	Center Measurement (L)
- 70 mm	Pipe Length Inside Joint (35mm x 2)
- 2 mm	Extra Measurement (2mm - 5 mm)
928 mm	Pipe Length (l)

A-001 Single Tee Joint

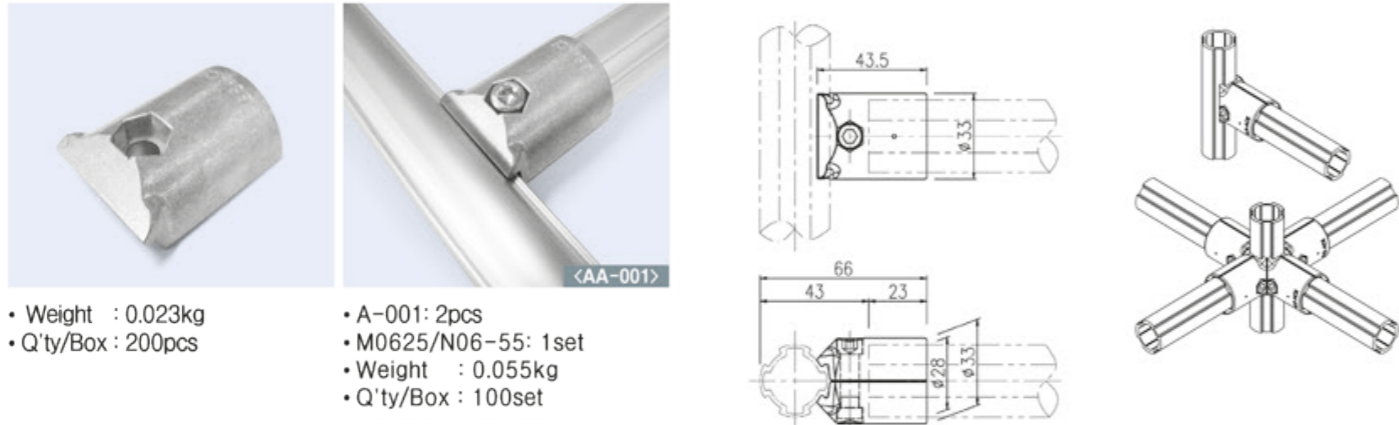

- Weight : 0.023kg
- Q'ty/Box : 200pcs
- A-001: 2pcs
- M0625/N06-55: 1set
- Weight : 0.055kg
- Q'ty/Box : 100set

A-001C Single Tee Joint (for round pipes)

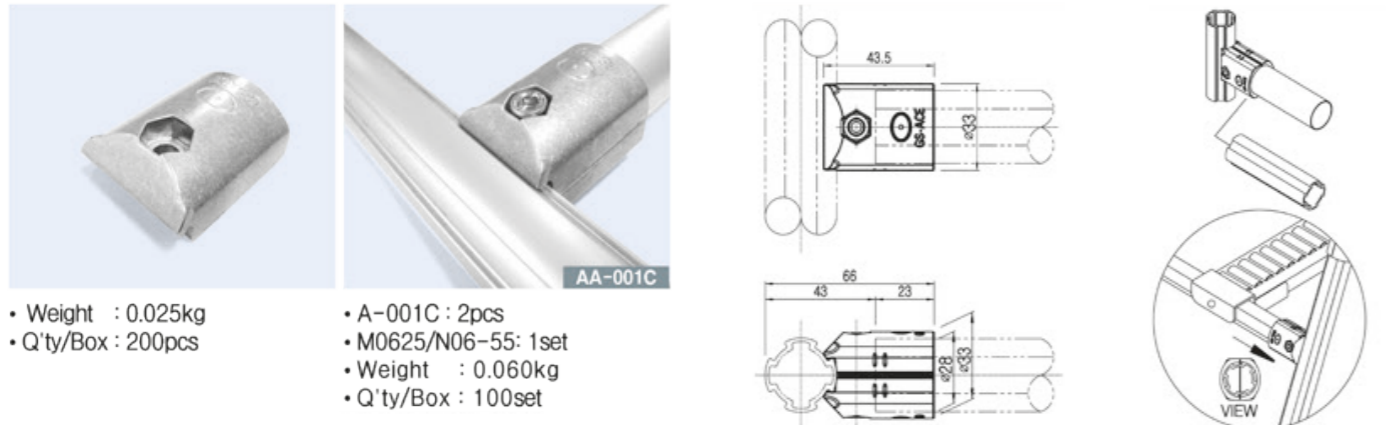

- Weight : 0.025kg
- Q'ty/Box : 200pcs
- A-001C: 2pcs
- M0625/N06-55: 1set
- Weight : 0.060kg
- Q'ty/Box : 100set

A-003 Outer Elbow Joint

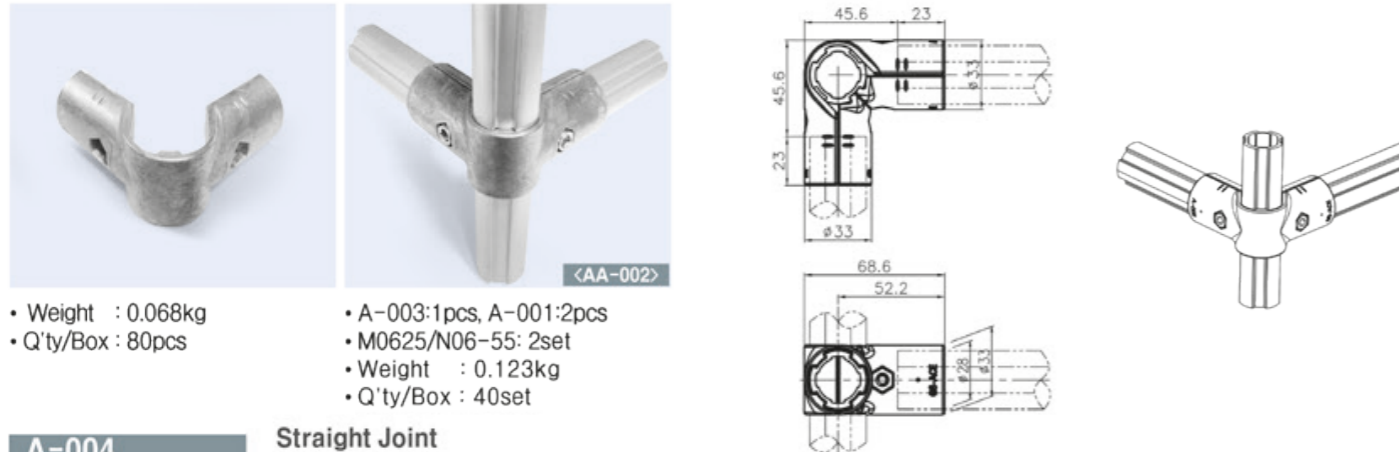

- Weight : 0.068kg
- Q'ty/Box : 80pcs
- A-003: 1pcs, A-001: 2pcs
- M0625/N06-55: 2set
- Weight : 0.123kg
- Q'ty/Box : 40set

A-004 Straight Joint

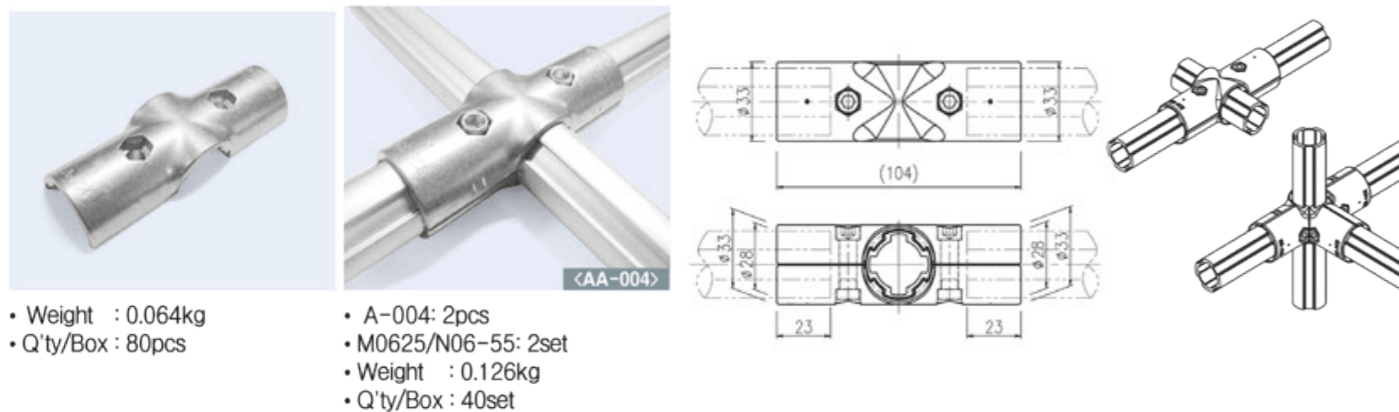

- Weight : 0.064kg
- Q'ty/Box : 80pcs
- A-004: 2pcs
- M0625/N06-55: 2set
- Weight : 0.126kg
- Q'ty/Box : 40set

A-007B Swivel Joint (Angle Adjustable)

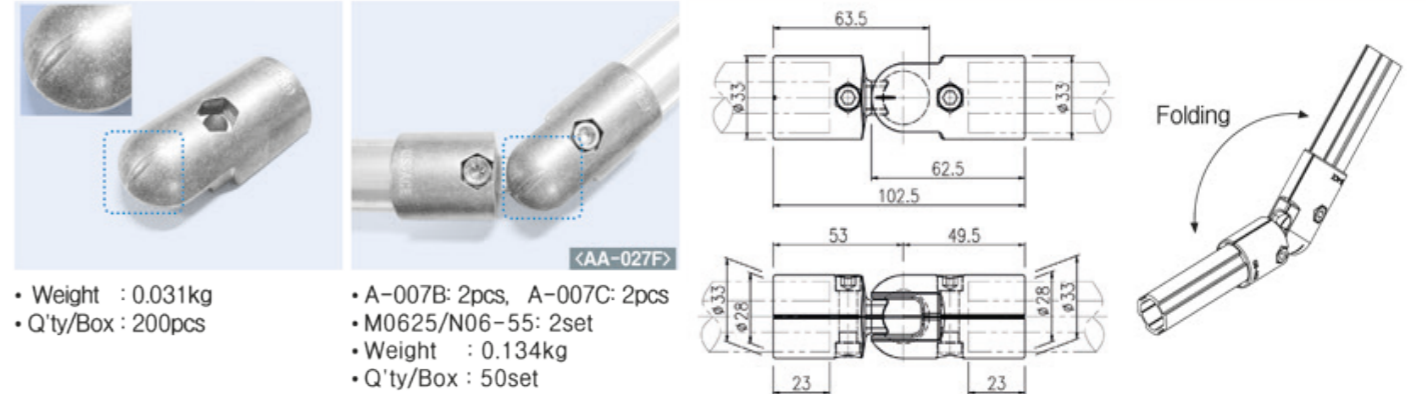

- Weight : 0.031kg
- Q'ty/Box : 200pcs
- A-007B: 2pcs, A-007C: 2pcs
- M0625/N06-55: 2set
- Weight : 0.134kg
- Q'ty/Box : 50set

A-007C Swivel Joint (Angle Adjustable)

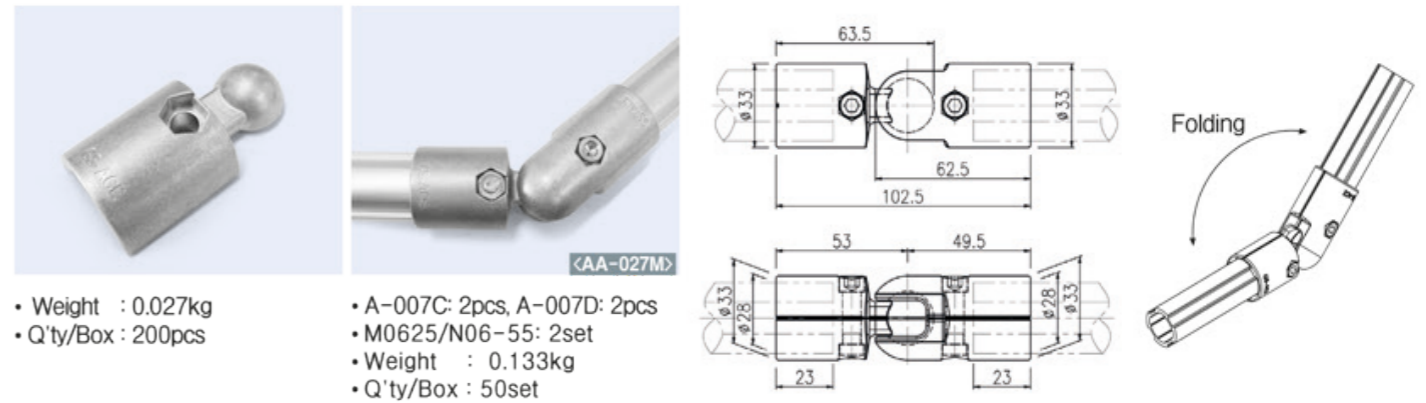

- Weight : 0.027kg
- Q'ty/Box : 200pcs
- A-007C: 2pcs, A-007D: 2pcs
- M0625/N06-55: 2set
- Weight : 0.133kg
- Q'ty/Box : 50set

A-007D Swivel Joint (Revolution, Angle Adjustable)

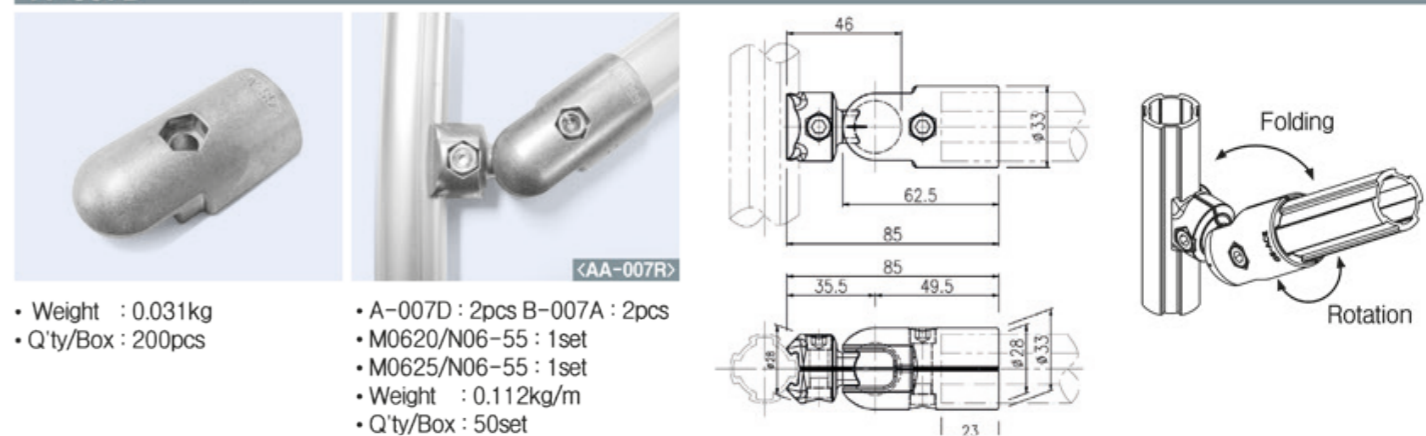

- Weight : 0.031kg
- Q'ty/Box : 200pcs
- A-007D: 2pcs B-007A: 2pcs
- M0620/N06-55: 1set
- M0625/N06-55: 1set
- Weight : 0.112kg/m
- Q'ty/Box : 50set

A-009 Double Tee Joint

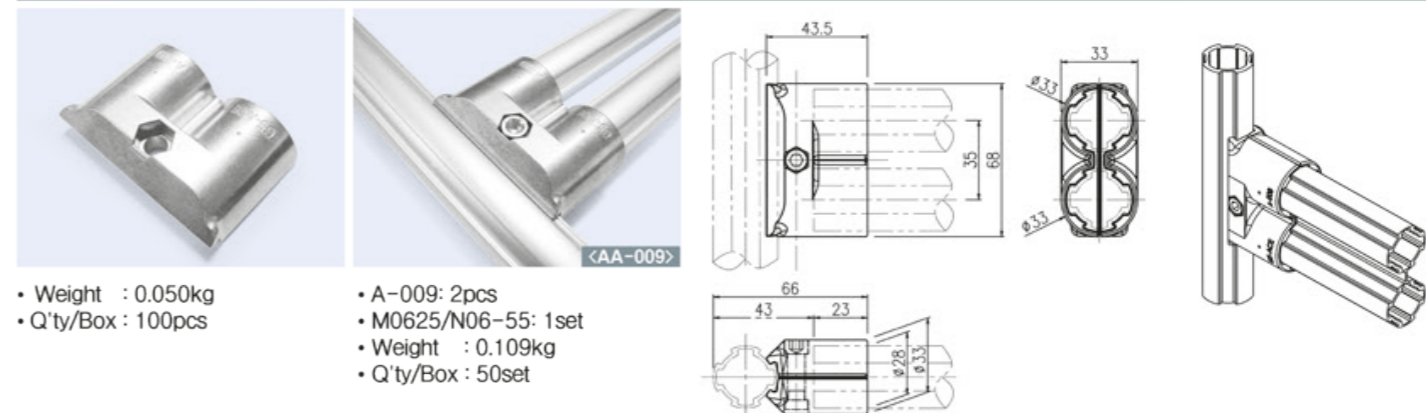

- Weight : 0.050kg
- Q'ty/Box : 100pcs
- A-009: 2pcs
- M0625/N06-55: 1set
- Weight : 0.109kg
- Q'ty/Box : 50set

A-013L, A-013R 45° Joint

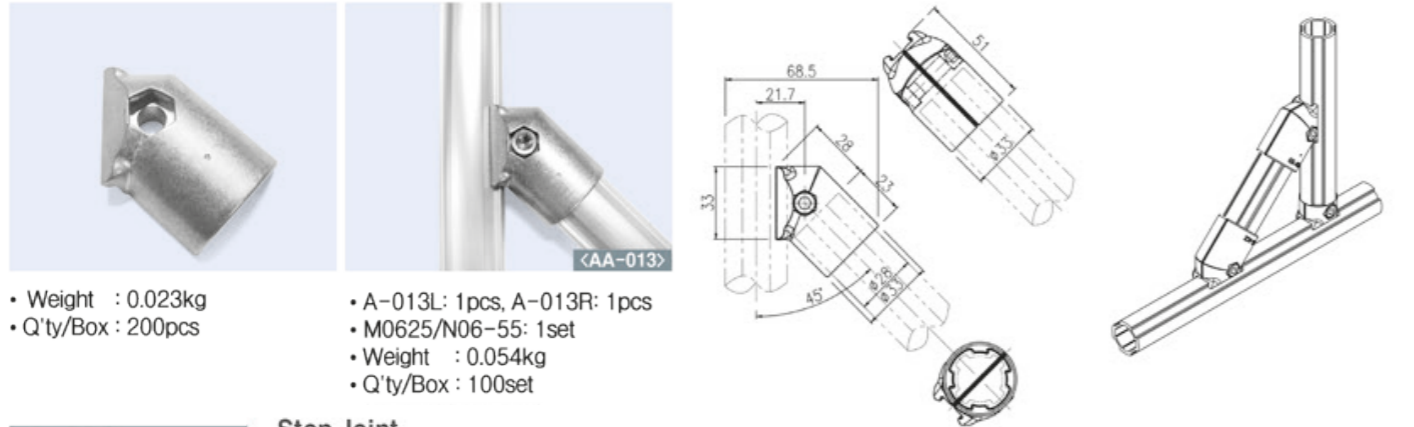

- Weight : 0.023kg
- Q'ty/Box : 200pcs
- A-013L: 1pcs, A-013R: 1pcs
- M0625/N06-55: 1set
- Weight : 0.054kg
- Q'ty/Box : 100set

A-023 Stop Joint

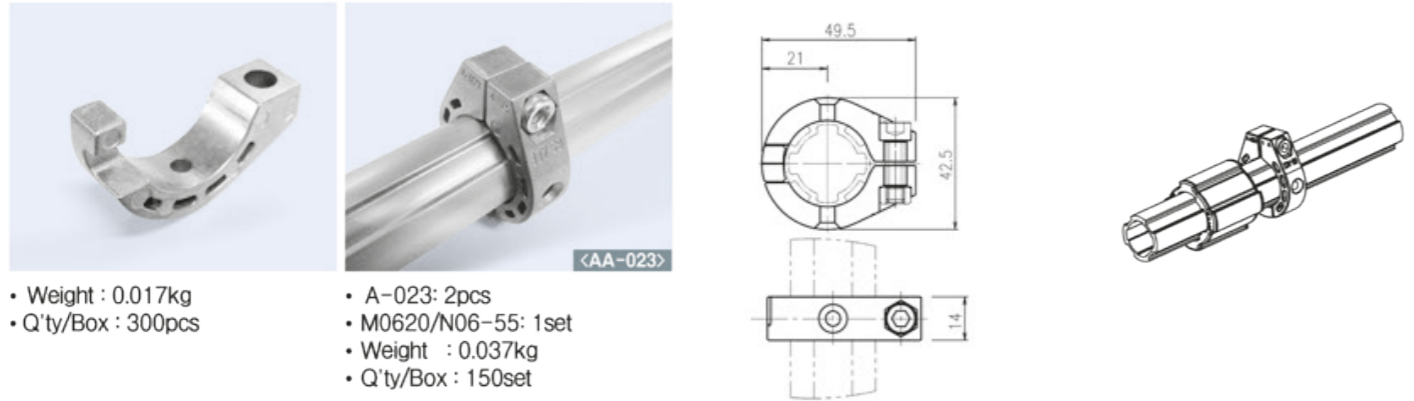

- Weight : 0.017kg
- Q'ty/Box : 300pcs
- A-023: 2pcs
- M0620/N06-55: 1set
- Weight : 0.037kg
- Q'ty/Box : 150set

A-028 Parallel Joint

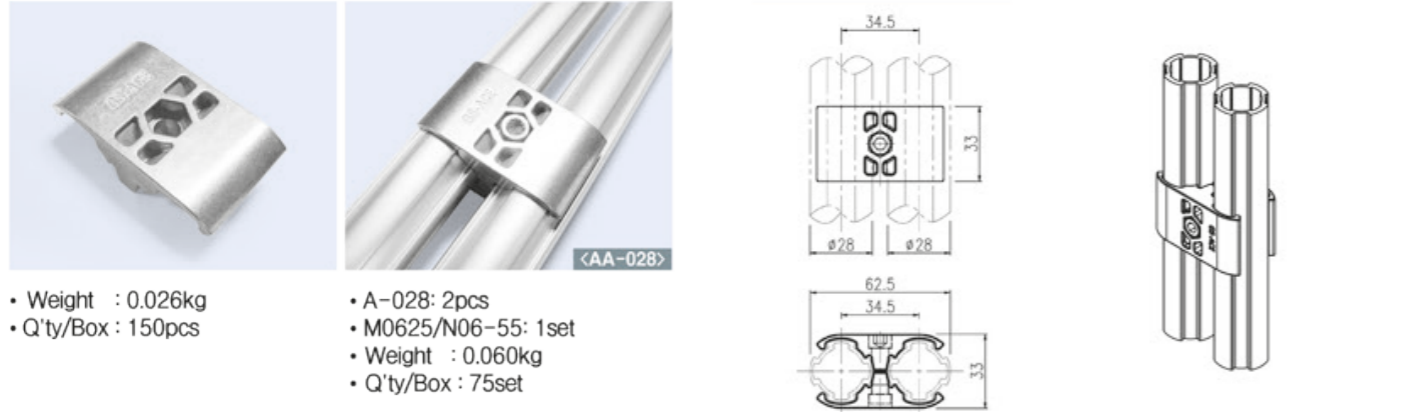

- Weight : 0.026kg
- Q'ty/Box : 150pcs
- A-028: 2pcs
- M0625/N06-55: 1set
- Weight : 0.060kg
- Q'ty/Box : 75set

A-090 90° Elbow Joint

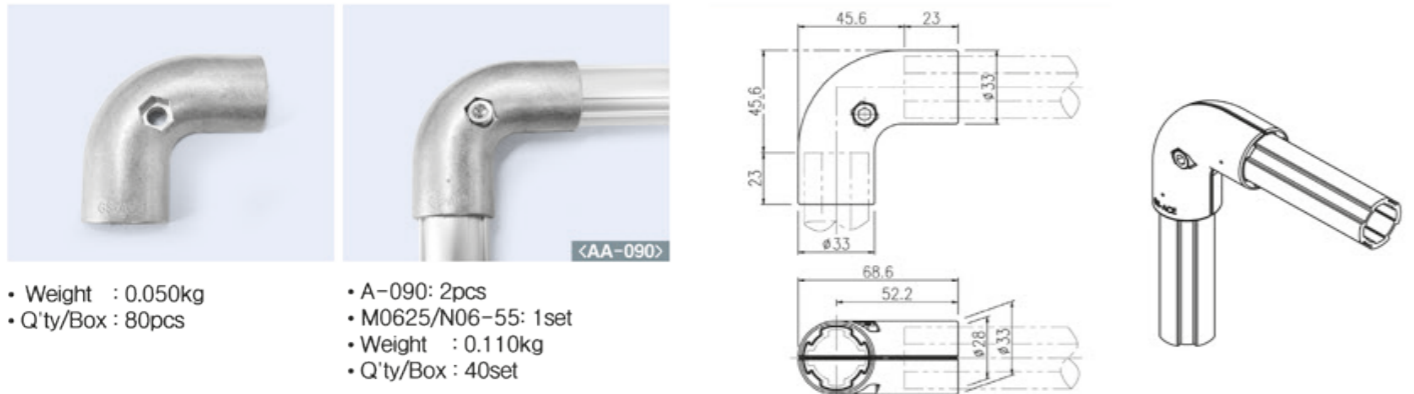

- Weight : 0.050kg
- Q'ty/Box : 80pcs
- A-090: 2pcs
- M0625/N06-55: 1set
- Weight : 0.110kg
- Q'ty/Box : 40set

B-001 Single Tee Joint

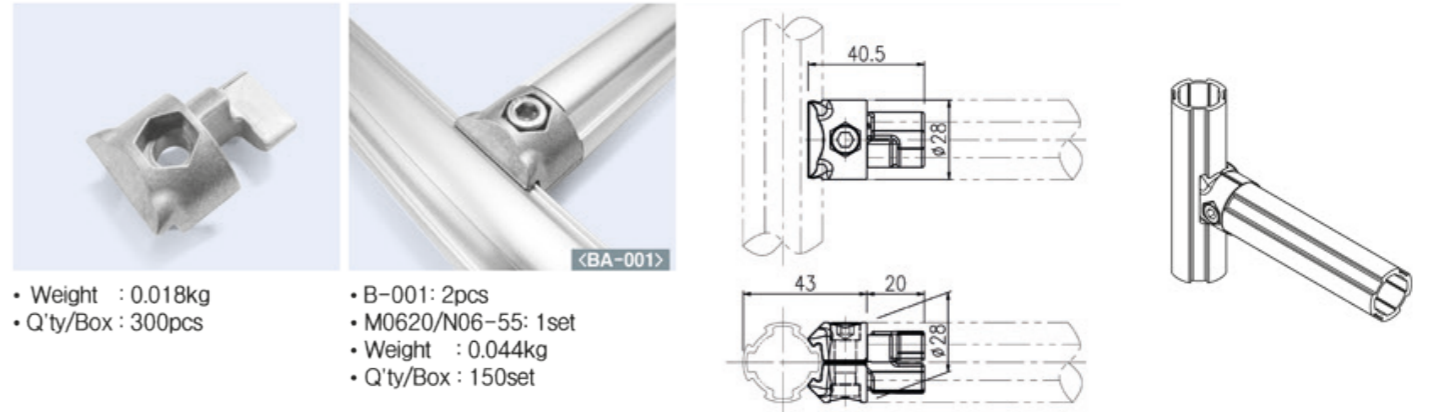

- Weight : 0.018kg
- Q'ty/Box : 300pcs
- B-001: 2pcs
- M0620/N06-55: 1set
- Weight : 0.044kg
- Q'ty/Box : 150set

B-006 90° Offset Joint

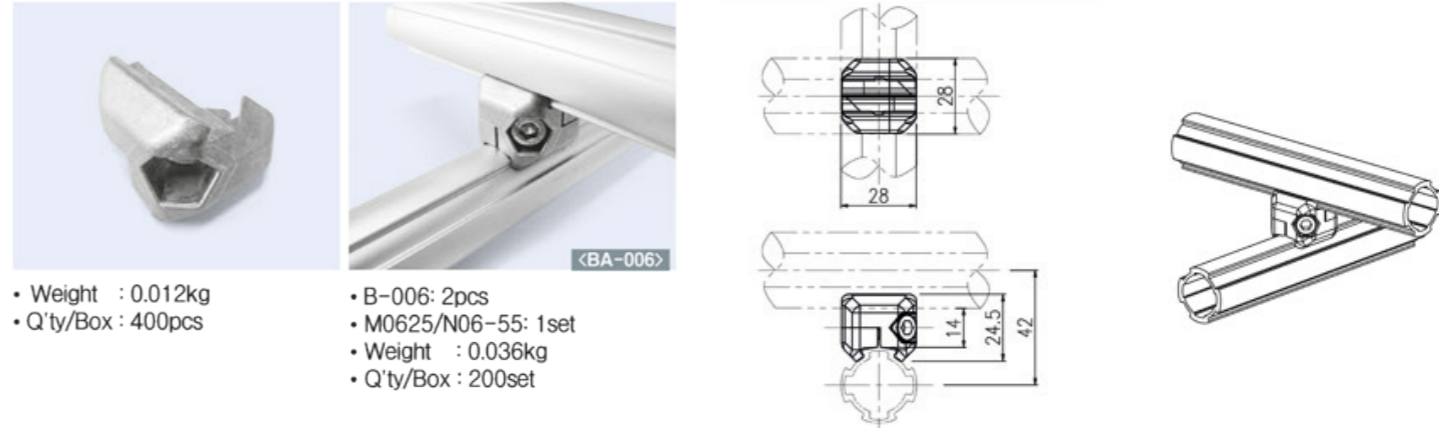

- Weight : 0.012kg
- Q'ty/Box : 400pcs
- B-006: 2pcs
- M0625/N06-55: 1set
- Weight : 0.036kg
- Q'ty/Box : 200set

B-007A Swivel Joint (Revolution, Angle Adjustable)

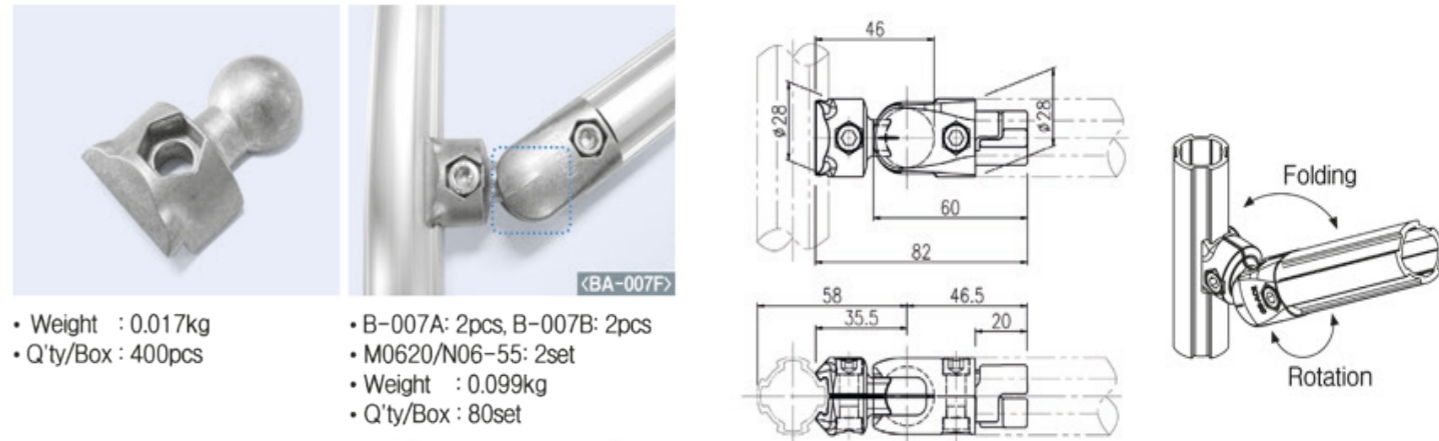

- Weight : 0.017kg
- Q'ty/Box : 400pcs
- B-007A: 2pcs, B-007B: 2pcs
- M0620/N06-55: 2set
- Weight : 0.099kg
- Q'ty/Box : 80set

B-007B Swivel Joint (Angle Adjustable)

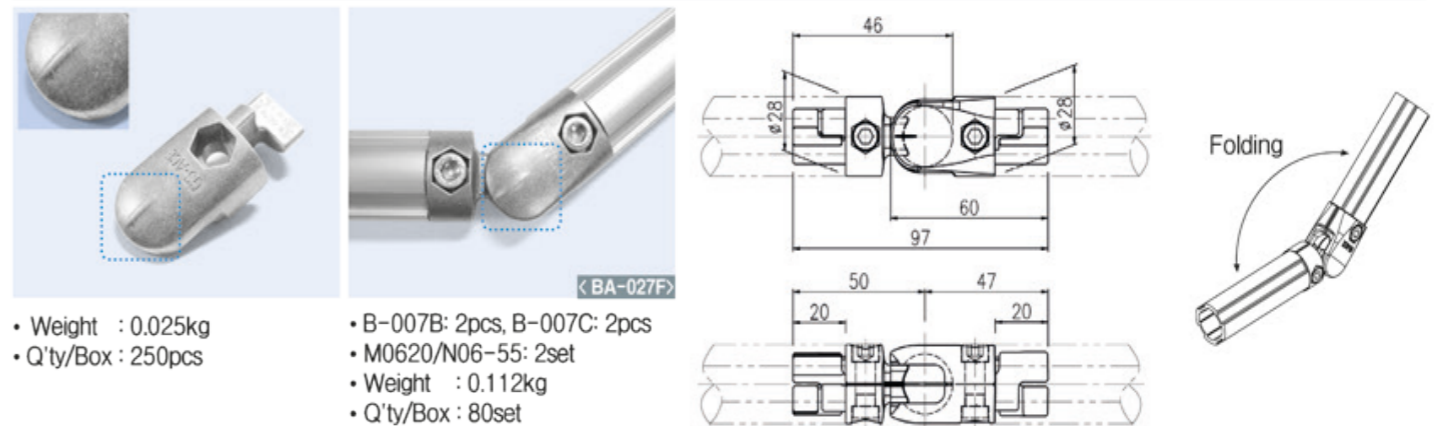

- Weight : 0.025kg
- Q'ty/Box : 250pcs
- B-007B: 2pcs, B-007C: 2pcs
- M0620/N06-55: 2set
- Weight : 0.112kg
- Q'ty/Box : 80set

B-007C Swivel Joint (Angle Adjustable)

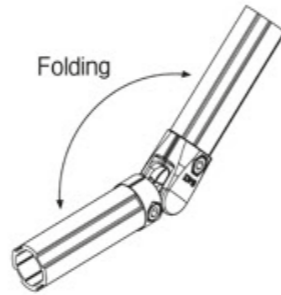
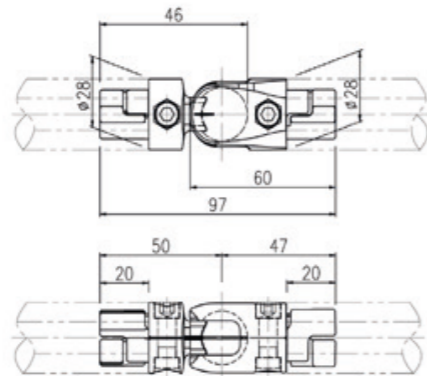

- Weight : 0.023kg
- Q'ty/Box : 250pcs
- B-007C: 2pcs, B-007D: 2pcs
- M0620/N06-55: 2set
- Weight : 0.111kg
- Q'ty/Box : 80set

<BA-027M>

B-007D Swivel Joint (Revolution, Angle Adjustable)

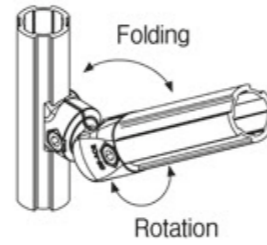
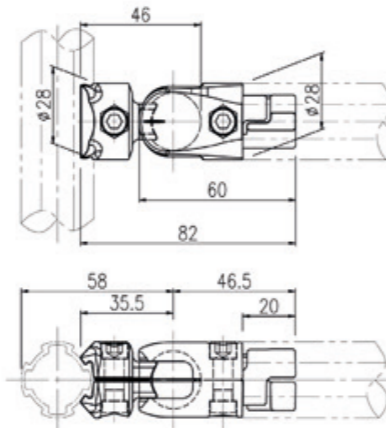

- Weight : 0.025kg
- Q'ty/Box : 250pcs
- B-007A: 2pcs, B-007D: 2pcs
- M0620/N06-55: 2set
- Weight : 0.098kg
- Q'ty/Box : 80set

<BA-007R>

B-008 Parallel Joint

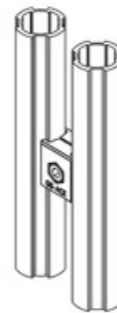
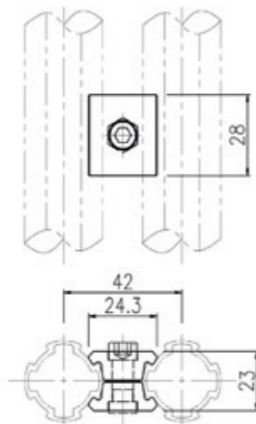
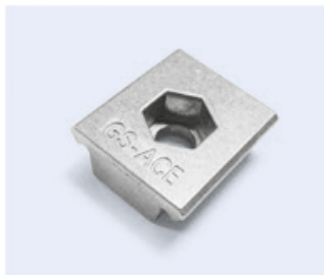

- Weight : 0.013kg
- Q'ty/Box : 400pcs
- B-008: 2pcs
- M0620/N06-55: 1set
- Weight : 0.032kg
- Q'ty/Box : 200set

<BA-008>

B-011 Parallel Joint

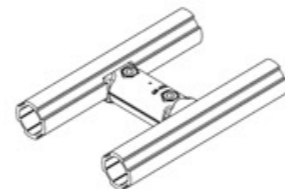
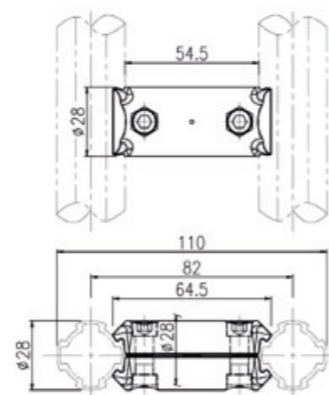

- Weight : 0.030kg
- Q'ty/Box : 200pcs
- B-011: 2pcs
- M0620/N06-55: 2set
- Weight : 0.075kg
- Q'ty/Box : 100set

<BA-011>

B-013L, B-013R 45° Joint

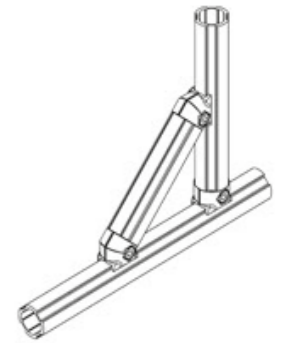
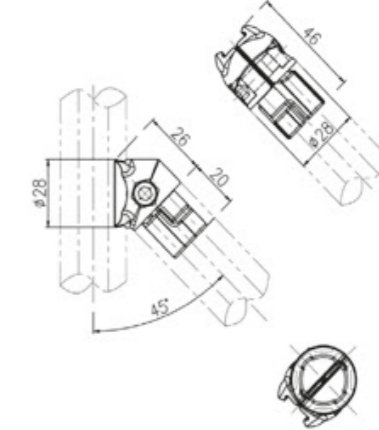

- Weight : 0.018kg
- Q'ty/Box : 300pcs
- B-013L: 1pcs, B-013R: 1pcs
- M0620/N06-55: 1set
- Weight : 0.043kg
- Q'ty/Box : 150set

<BA-013>

B-090 90° Elbow Joint

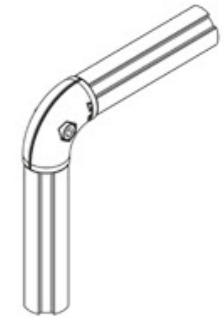
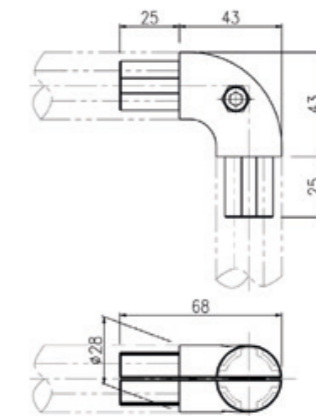

- Weight : 0.039kg
- Q'ty/Box : 120pcs
- B-090: 2pcs
- M0620/N06-55: 1set
- Weight : 0.086kg
- Q'ty/Box : 60set

<BA-090>



Unit : mm

A-401 Single Tee Joint

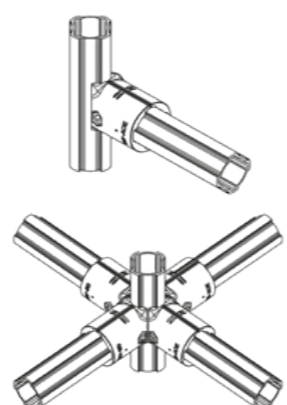
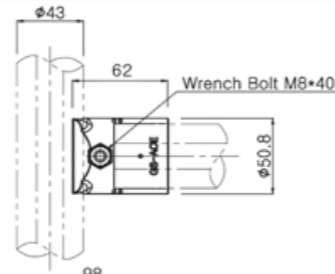
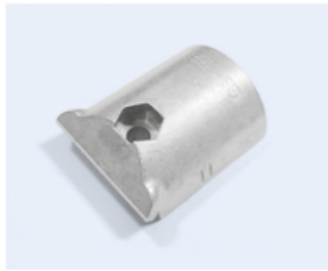

- Weight : 0.077kg
- Q'ty/Box : 60EA
- A-401 : 2pcs
- M0840/N08 : 1set
- Weight : 0.178kg
- Q'ty/Box : 35set

A-401W Single Tee Joint (Heavy Duty)

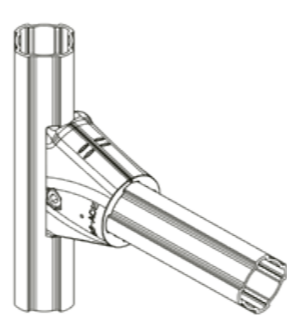
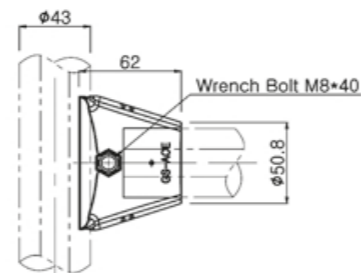
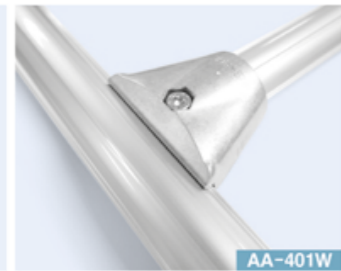
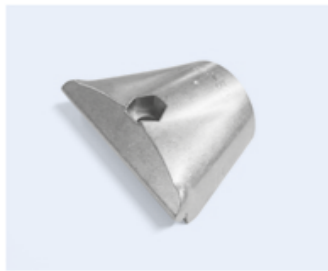

- Weight : 0.123kg
- Q'ty/Box : 40EA
- A-401W : 2pcs
- M0840/N08 : 1set
- Weight : 0.270kg
- Q'ty/Box : 20set

A-413L, A-413R 45° Joint

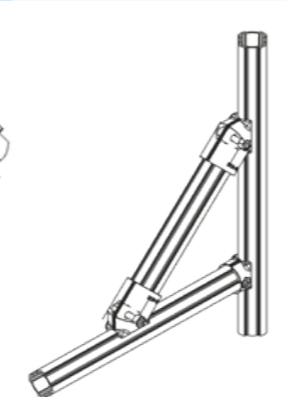
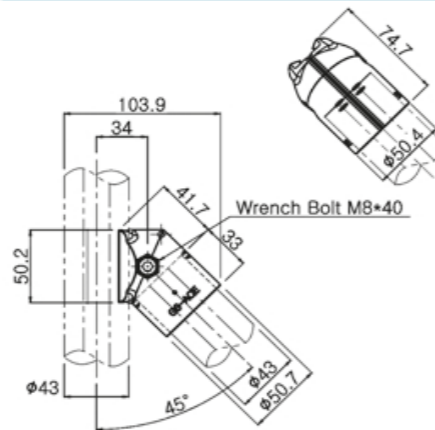

- Weight : 0.082kg
- Q'ty/Box : 50EA
- A-413L : 1pcs, A-413R : 1pcs
- M0840/N08 : 1set
- Weight : 0.188kg
- Q'ty/Box : 25set

Unit : mm

A-490 90° Elbow Joint

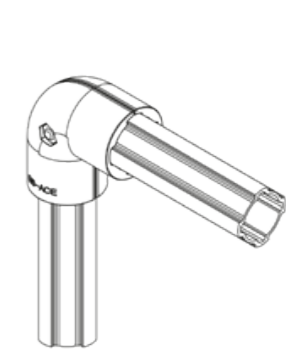
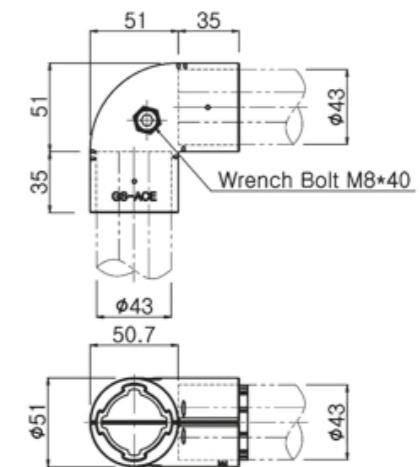

- Weight : 0.131kg
- Q'ty/Box : 30EA
- A-490 : 2pcs
- M0840/N08 : 1set
- Weight : 0.286kg
- Q'ty/Box : 15set

B-401 Single Tee Joint

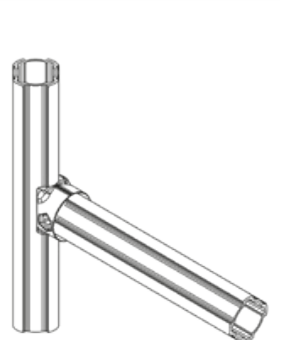
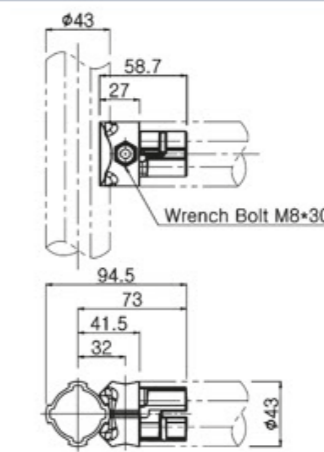

- Weight : 0.061kg
- Q'ty/Box : 100EA
- B-401 : 2pcs
- M0830/N08 : 1set
- Weight : 0.143kg
- Q'ty/Box : 50set

B-407A Swivel Joint (Angle Adjustable)

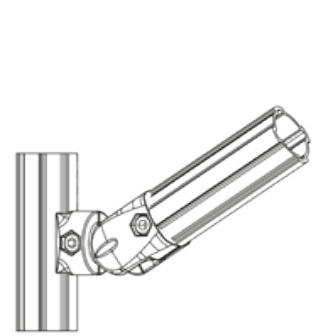
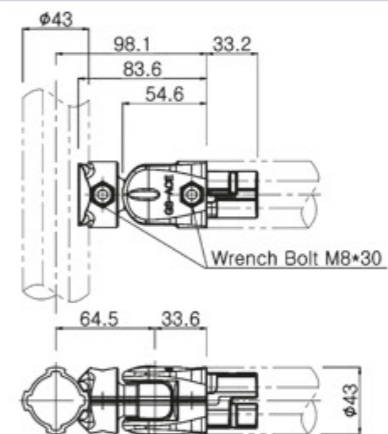

- Weight : 0.049kg
- Q'ty/Box : 120EA
- B-407A : 2pcs, B-407B : 2pcs
- M0830/N08 : 2set
- Weight : 0.306kg
- Q'ty/Box : 20set



Unit : mm

Unit : mm

B-407B Swivel Joint (Angle Adjustable)

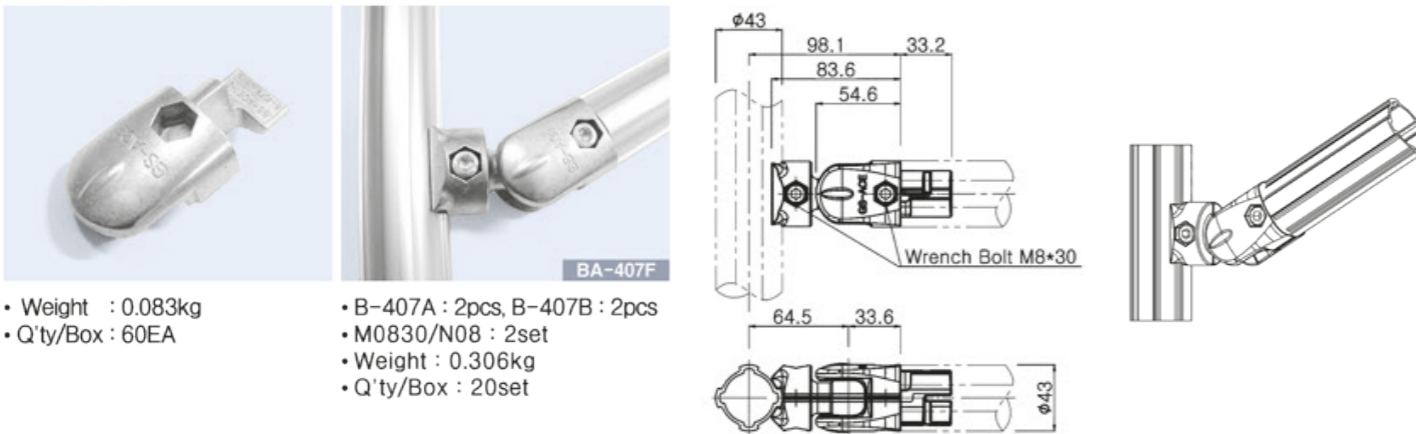

- Weight : 0.083kg
- Q'ty/Box : 60EA
- B-407A : 2pcs, B-407B : 2pcs
- M0830/N08 : 2set
- Weight : 0.306kg
- Q'ty/Box : 20set

B-411 Parallel Joint

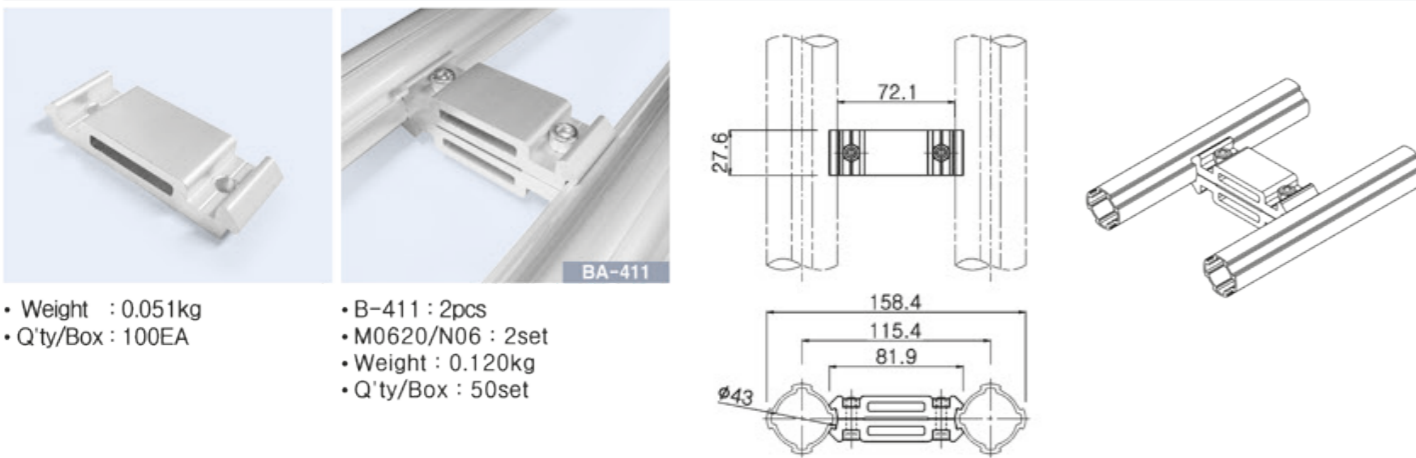

- Weight : 0.051kg
- Q'ty/Box : 100EA
- B-411 : 2pcs
- M0620/N06 : 2set
- Weight : 0.120kg
- Q'ty/Box : 50set

Test Condition

1. Test Speed : 5mm / min
2. Temperature : 23°C

Classification	Coated Pipe		Stainless Steel Pipe	
	Ø28 x t0.7	Ø28 x t1.0	Ø28 x t0.7	Ø28 x t1.2
Direction : X	More Than 80kg	More Than 80kg	More Than 80 kg	More Than 80 kg
Direction : Y	More Than 80kg	More Than 80kg	More Than 80 kg	More Than 80 kg

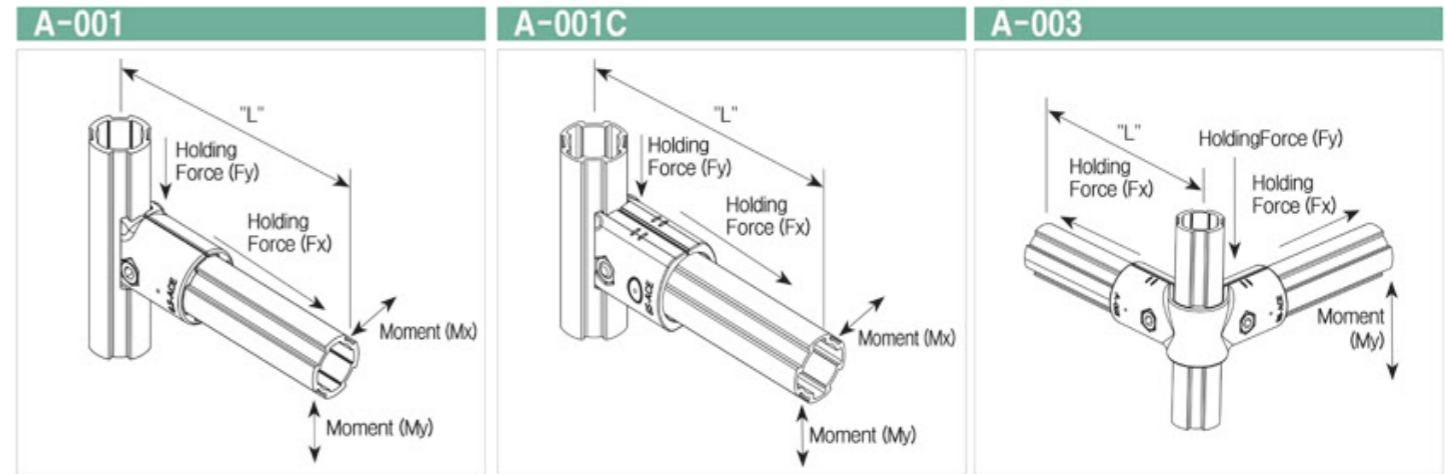

Holding Force (kgf)	A-001		A-001C		A-003	
	Fx	80	Fx	80	Fx	80
	Fy	80	Fy	80	Fy	80
Moment (kgf) (L=110mm)	Mx	6	Mx	5	My	16
	My	12	My	10		

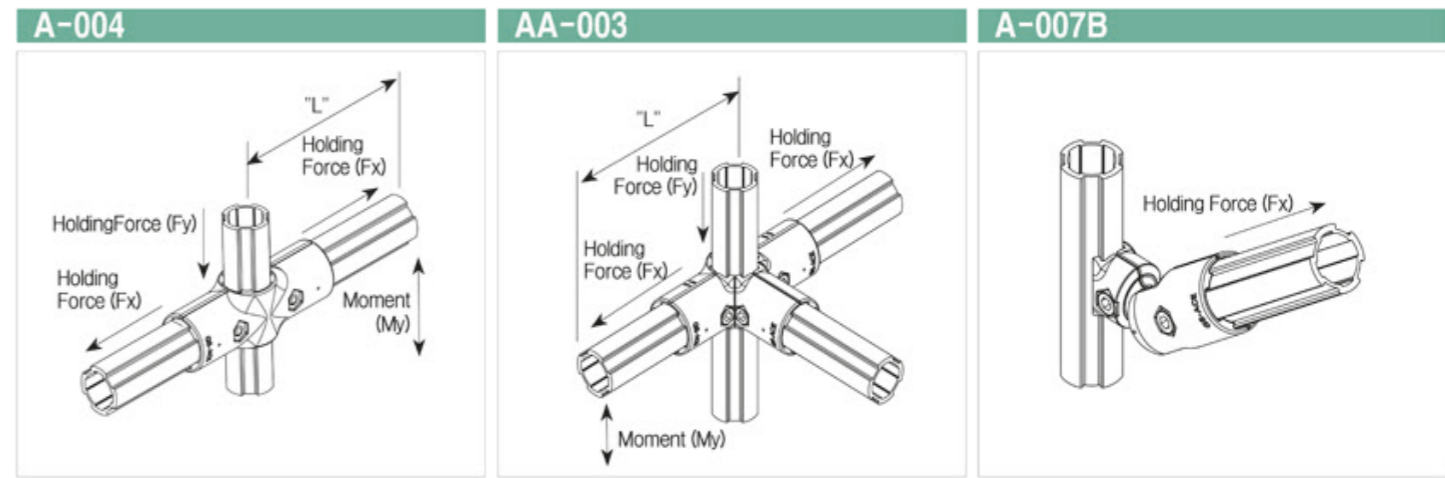

Holding Force (kgf)	A-004		AA-003		A-007B	
	Fx	80	Fx	80	Fx	80
	Fy	80	Fy	80		
Moment (kgf) (L=110mm)	My	25	My	19		

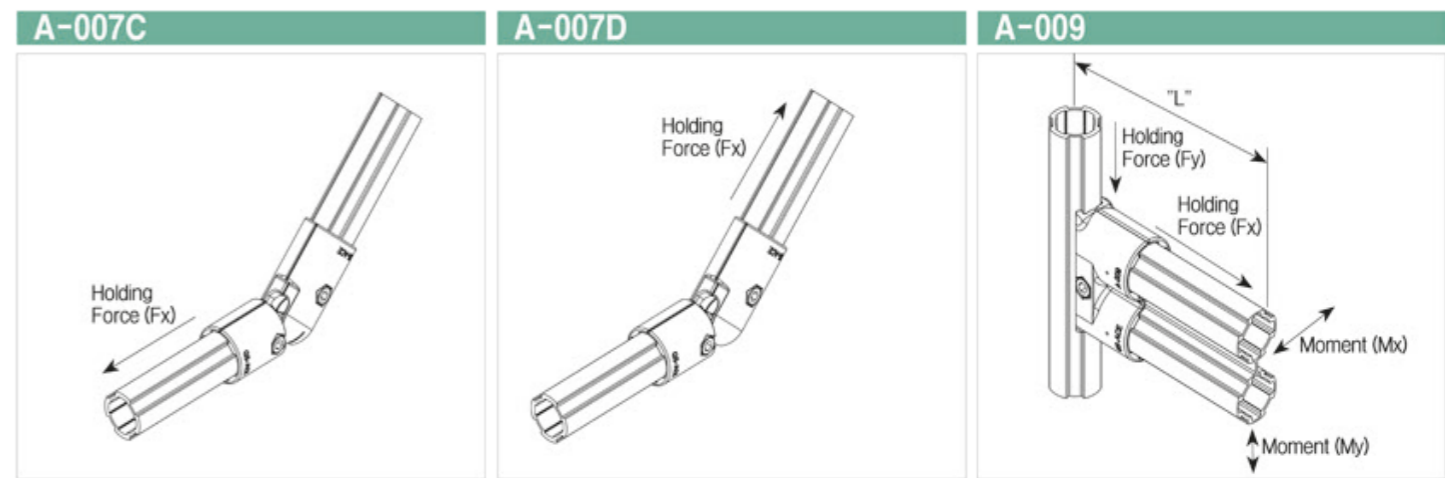



Holding Force (kgf)	A-007C		A-007D		A-009		
	Fx	80	Fx	80	Fx	150	
					Fy	200	
Moment (kgf) (L=110mm)					Mx	29	
					My	56	

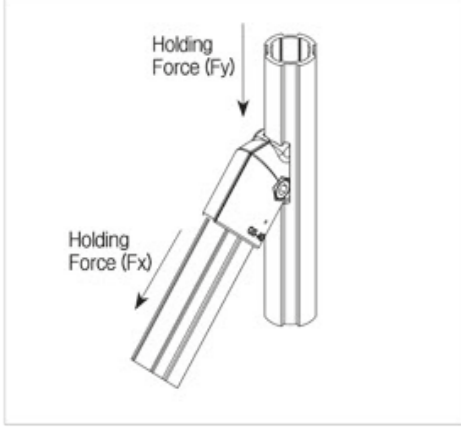
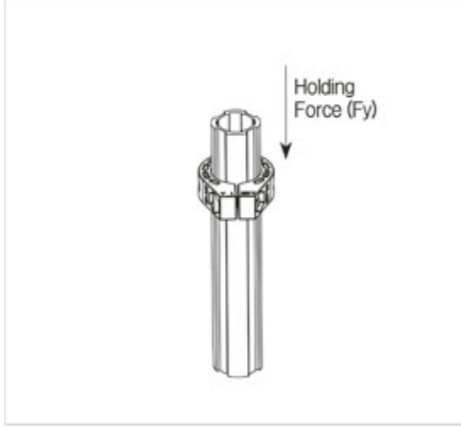
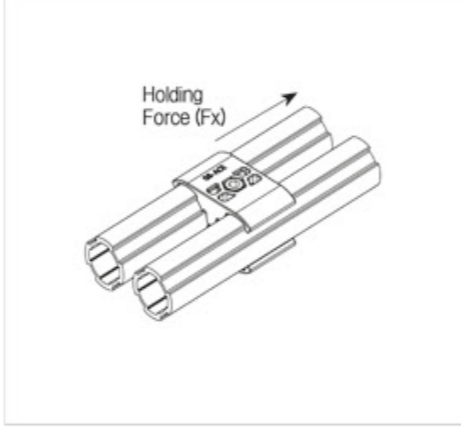

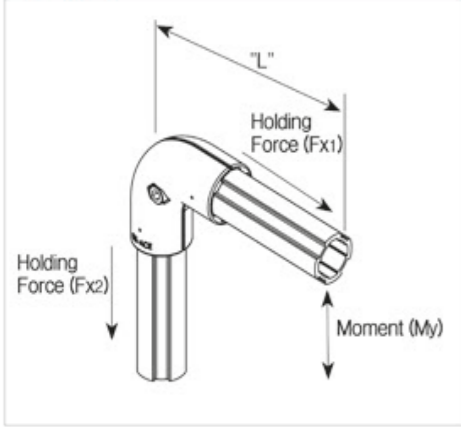
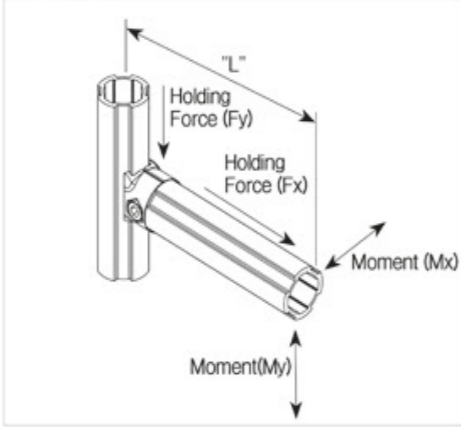
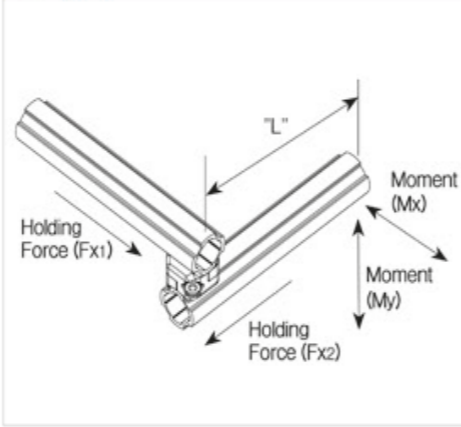
Unit : mm



A-013			A-023			A-028		
								
Holding Force (kgf)	Fx	80	Holding Force (kgf)	Fy	80	Holding Force (kgf)	Fx	80
	Fy	80		Fy	80		Fx	80

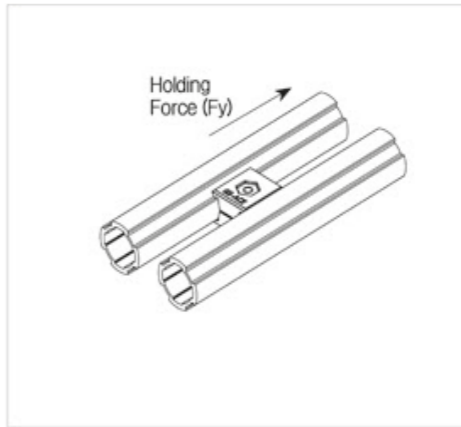

A-090			B-001			B-006			
									
Holding Force (kgf)	Fx1	80	Holding Force (kgf)	Fx	50	Holding Force (kgf)	Fx1	80	
	Fx2	80		Fy	80		Fy2	80	
Moment (kgf) (L=110mm)	My		21	Moment (kgf) (L=110mm)	Mx	5	Moment (kgf) (L=110mm)	Mx	9
					My	8		My	6

B-007A			B-007B			B-007C		
								
Holding Force (kgf)	Fy	80	Holding Force (kgf)	Fx	50	Holding Force (kgf)	Fx	50

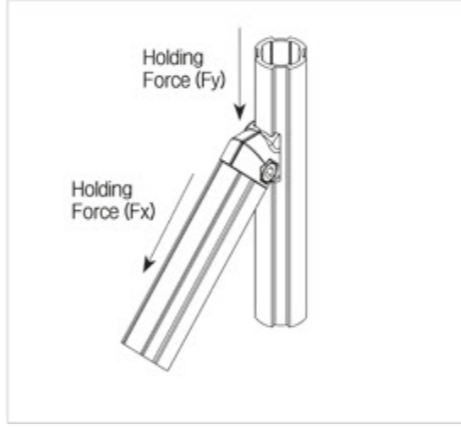
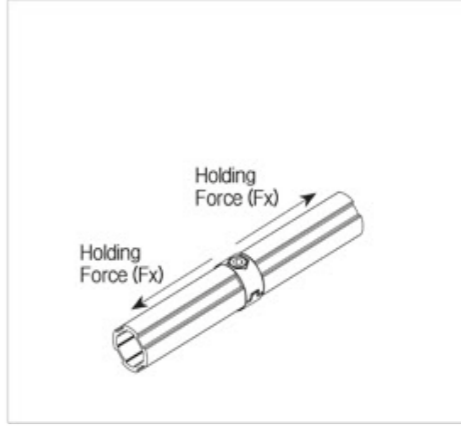
Unit : mm

B-007D			B-008			B-011		
								
Holding Force (kgf)	Fx	50	Holding Force (kgf)	Fy	80	Holding Force (kgf)	Fy	80
	Fy	80		Fy	80		Fy	80

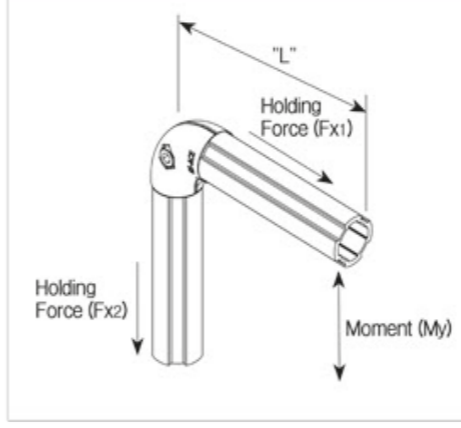
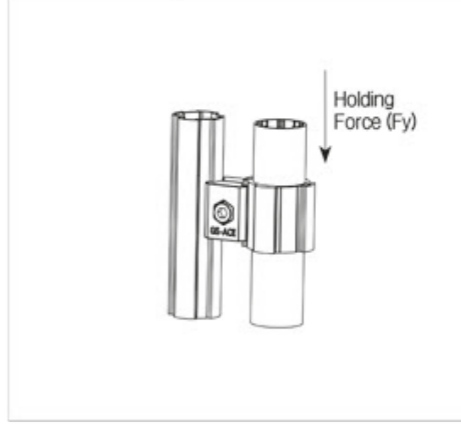
B-013			B-044			B-045		
								
Holding Force (kgf)	Fx	50	Holding Force (kgf)	Fx	80	Holding Force (kgf)	Fy	150
	Fy	80		Fy	80		Fy	150

B-090			APH-633L, APH-633R			BA2800A/B, BP2800A/B		
								
Holding Force (kgf)	Fx1	50	Holding Force (kgf)	Fy	80	Holding Force (kgf)	Fx	80
	Fx2	50		Fy	80		Fx	80
	Moment (kgf) (L=110mm)			My	13			

Example for ABS-620

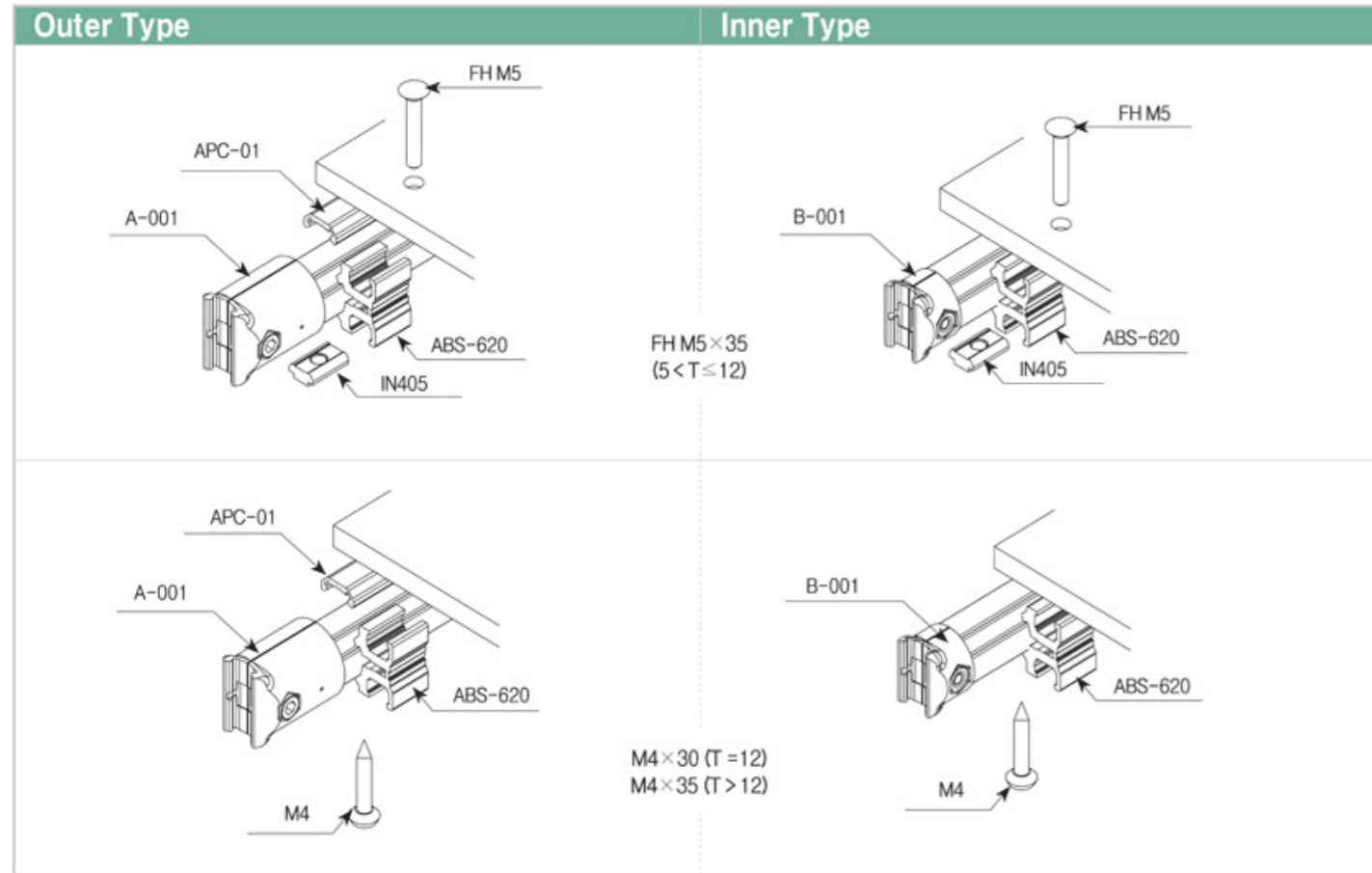

Example for B-017A-08

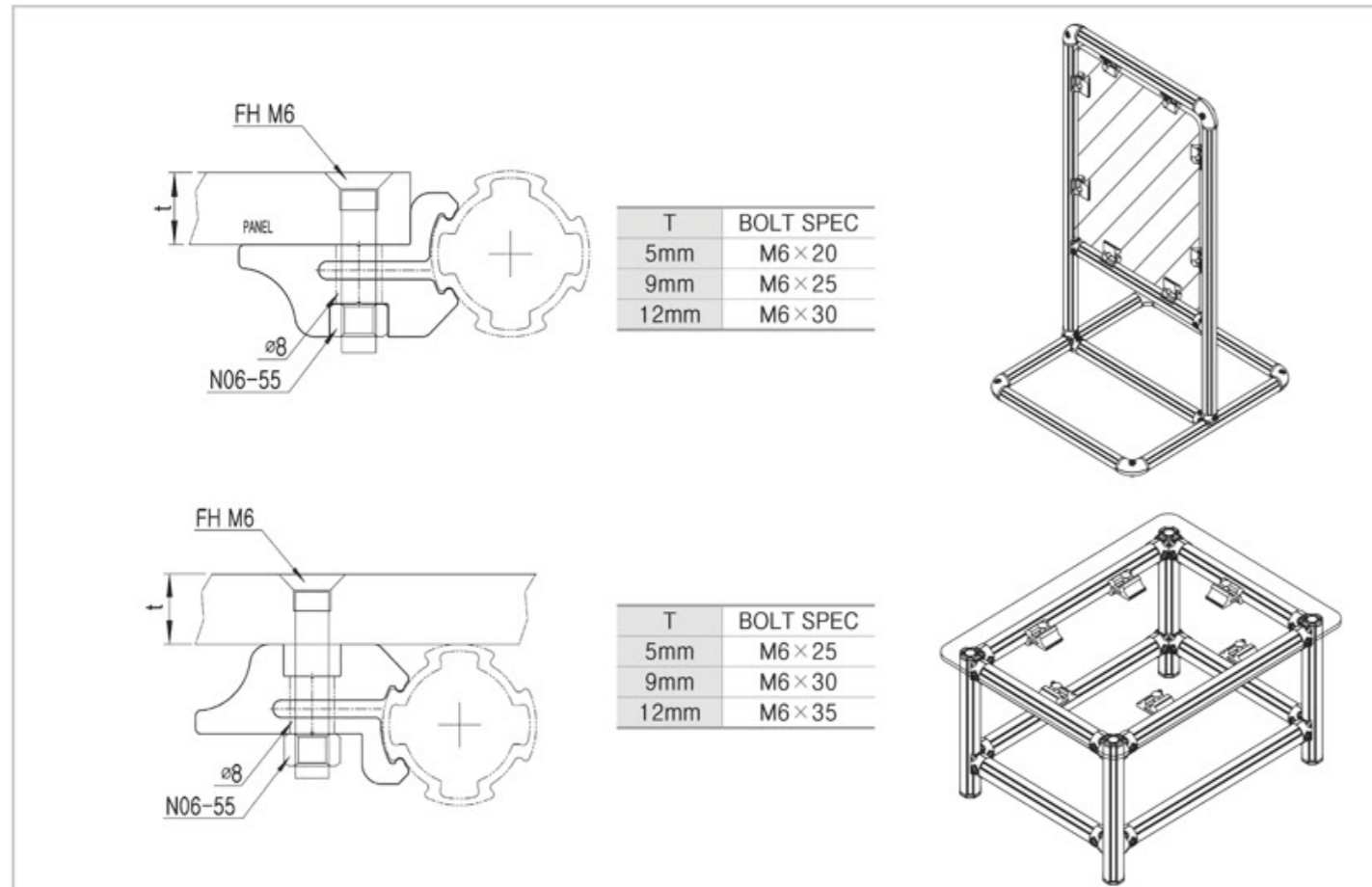

ALUMINIUM PROFILES

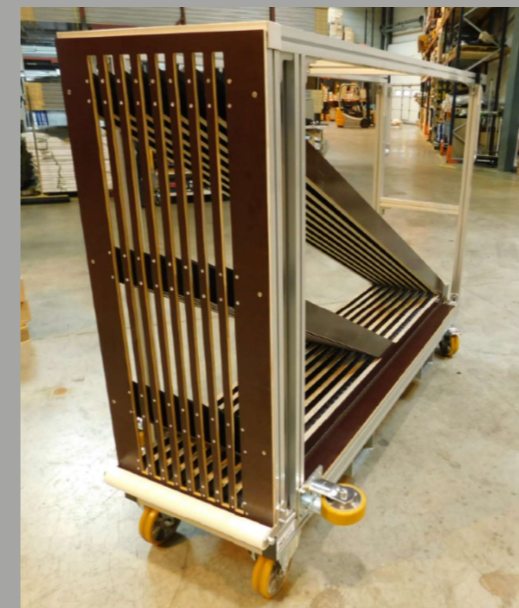
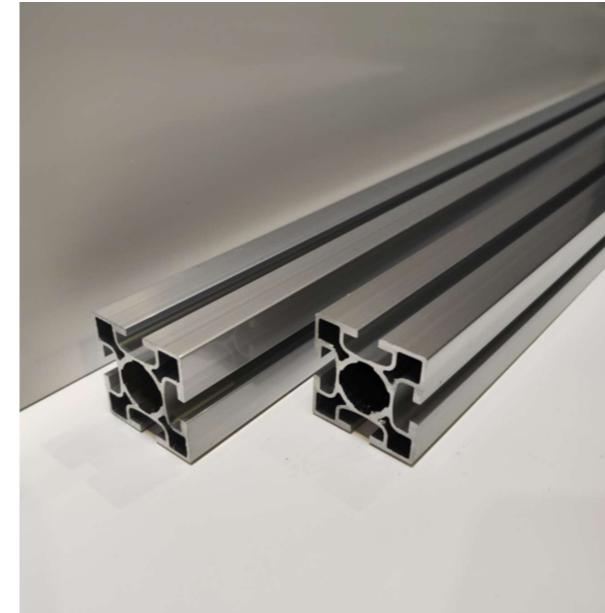

Unit : mm

Unit : mm

ASJ4545A



- Weight : 1.320 kg/m
- 4pcs/Bag, 90Bag/Pallet

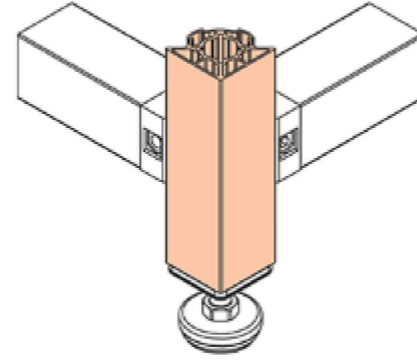
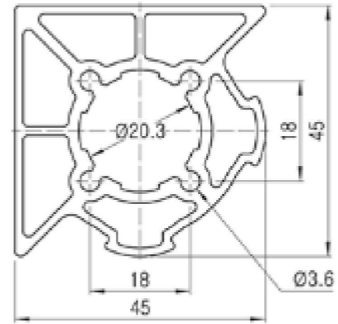

ASJ4545C

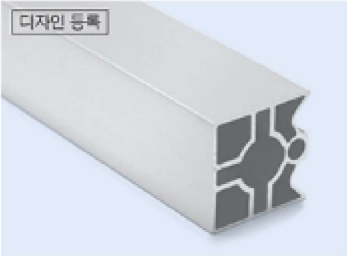

- Weight : 1.412 kg/m
- 4pcs/Bag, 90Bag/Pallet

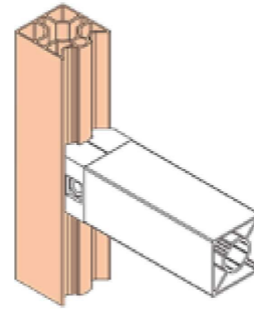
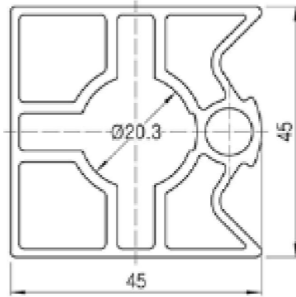

ASJ4545D

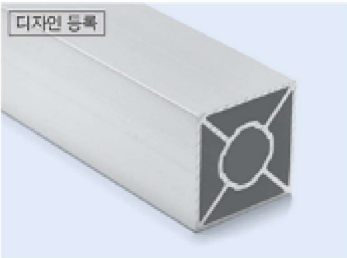

- Weight : 1.495 kg/m
- 4pcs/Bag, 90Bag/Pallet

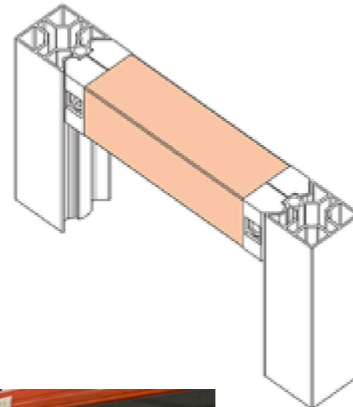
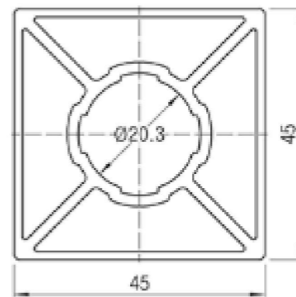

AST4545A

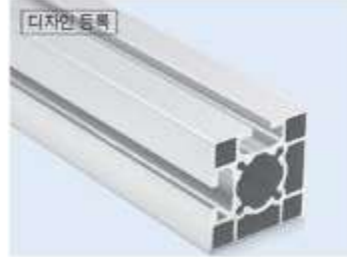

- Weight : 1.513 kg/m
- 4pcs/Bag, 90Bag/Pallet

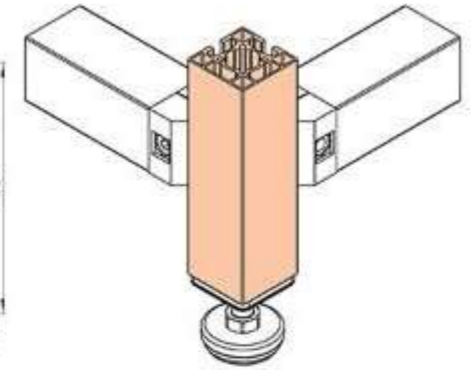
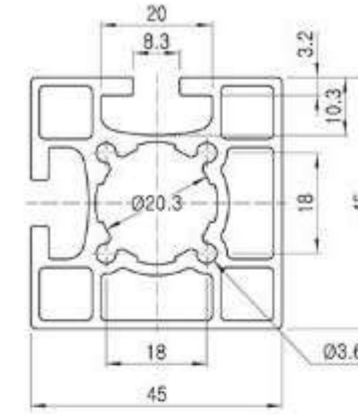

- Insert Nut : IN404~IN408
- Spring Nut : SN404~SN408

AST4545D

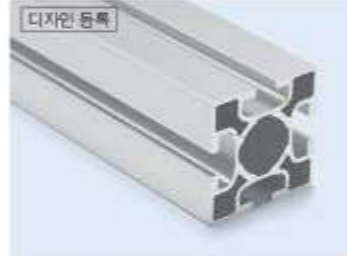

- Weight : 1.607 kg/m
- 4pcs/Bag, 90Bag/Pallet

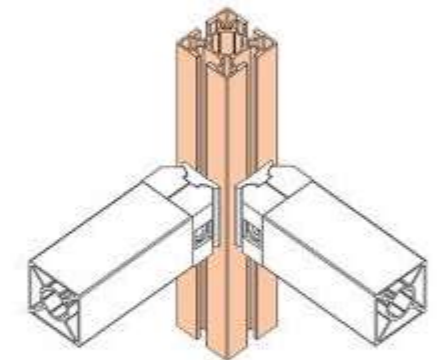
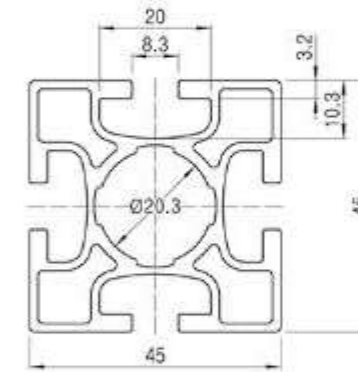

- Insert Nut : IN404~IN408
- Spring Nut : SN404~SN408

ASM4545C

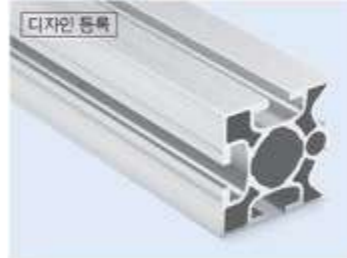

- Weight : 1.595 kg/m
- 4pcs/Bag, 90Bag/Pallet

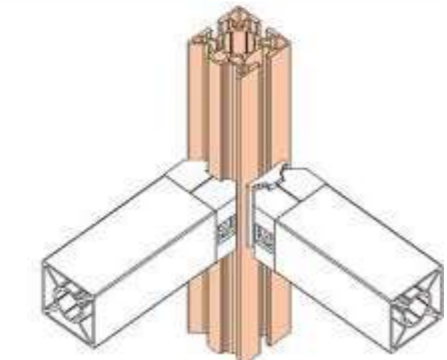
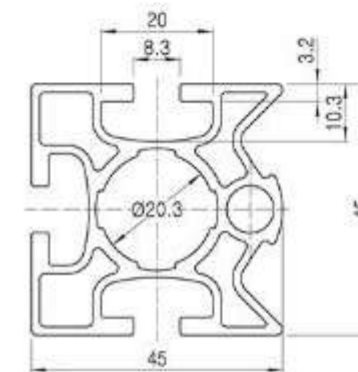

- Insert Nut : IN404~IN408
- Spring Nut : SN404~SN408

ACY-08A

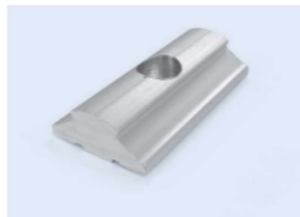

- Weight : 0.019kg
- Q'ty/Box : 300pcs

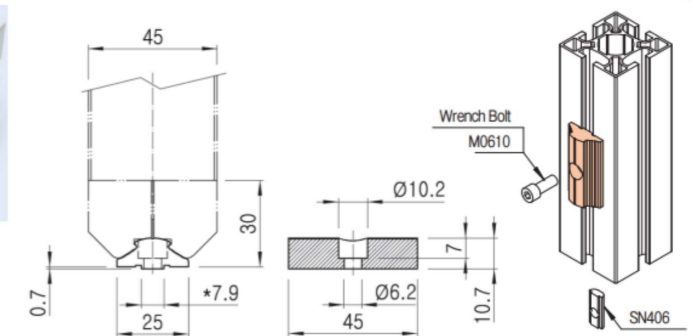

Unit : mm

45X45 ALUMINUM JOINTS & ACCESSORIES

E-001

실용신안 출원



EA-001

- Weight : 0.050kg
- Q'ty/Box : 100pcs

- E-001 : 2EA
- M0830/N08 : 1set
- Weight : 0.120kg
- Q'ty/Box : 50set

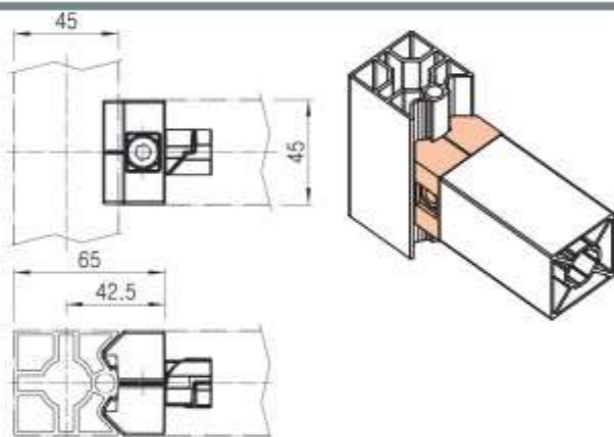

B-080A



- Weight : 0.062kg
- Q'ty/Box : 40pcs

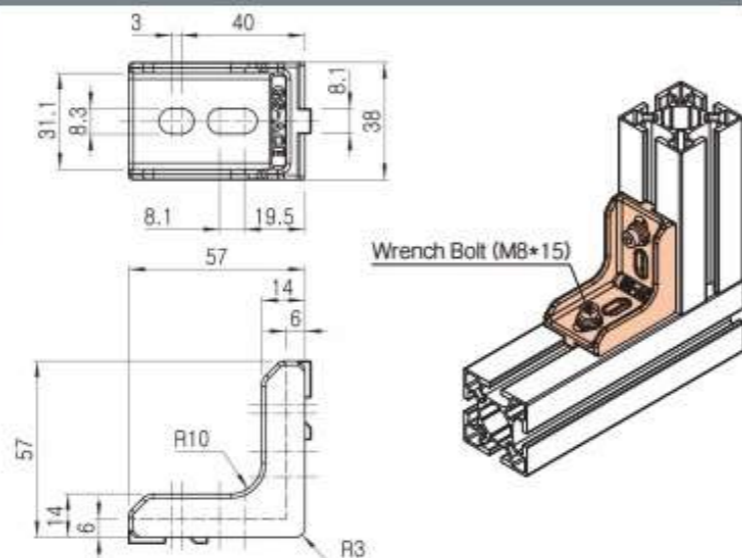

BA4545A/B



- Weight : 0.034kg
- Q'ty/Box : 200pcs

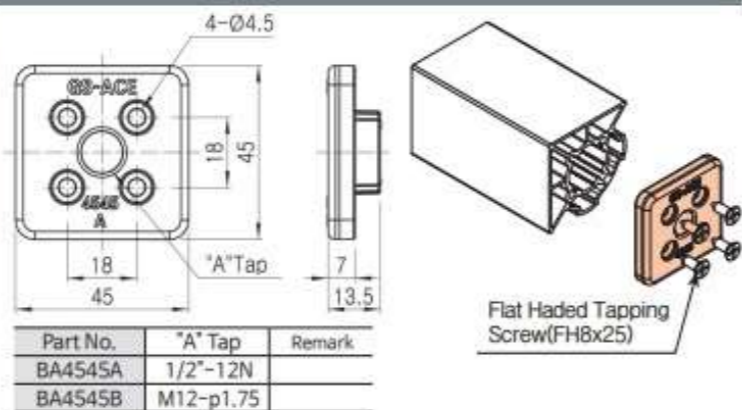

GAP-4545D



- Weight : 0.006kg
- Q'ty/Box : 1200pcs

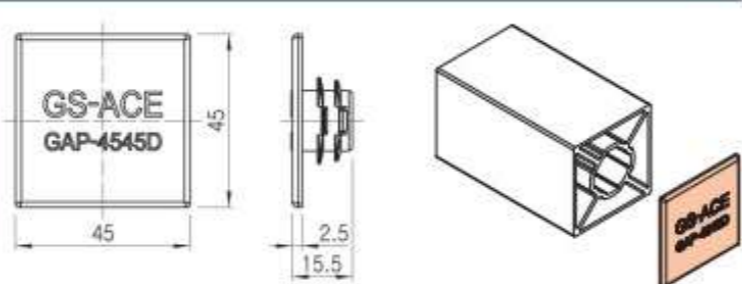

ROLLER TRACKS



SERIES

- GP - 25
- GP - 35
- GP - 40
- GP - 60
- GP - 70
- GP - 85

ROLLER TRACK NUMBERING SYSTEM

- WH = white
- GR = Gray
- BK = Black
- YL = Yellow

Color Code

- A : Round
- B : Flat
- BF : Flexible
- C : Flange
- D : Large
- HA : Taper
- M : Multi
- S : Slim
- SR : STS Covered roller

Roller Type

CHOOSE FOR THE ROLLER TYPE

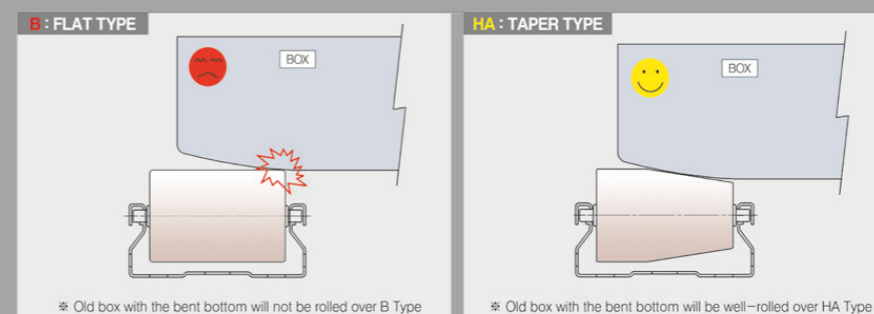

GP 40 36 A

Pitch

Serie / Frame Size

Unit : mm

BENDING STRENGTH FOR PIPE

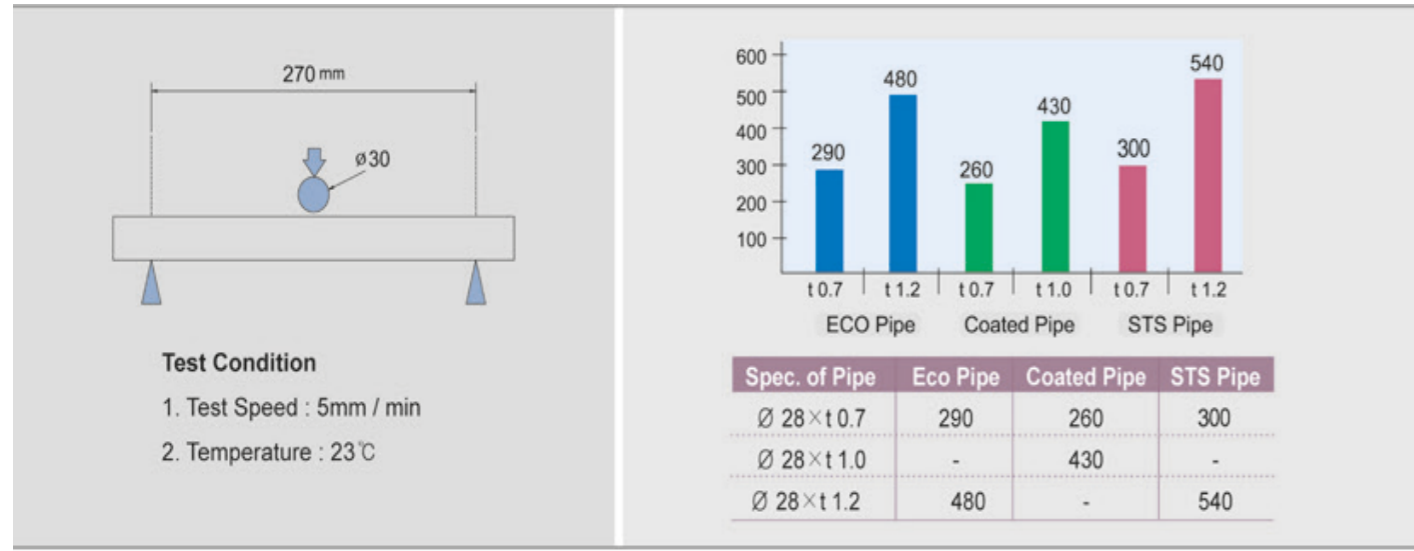

BENDING STRENGTH FOR ROLLER TRACK

Unit :kgf

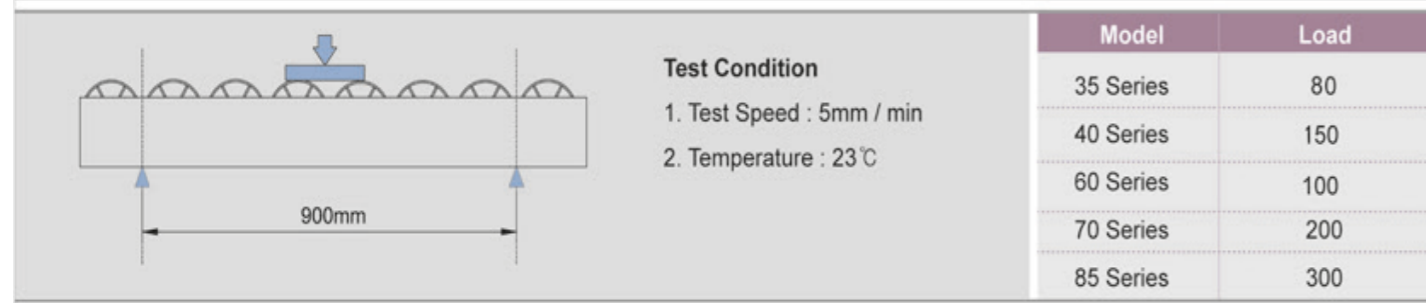

BENDING STRENGTH OF WHEEL SUBASSEMBL

Unit :kgf

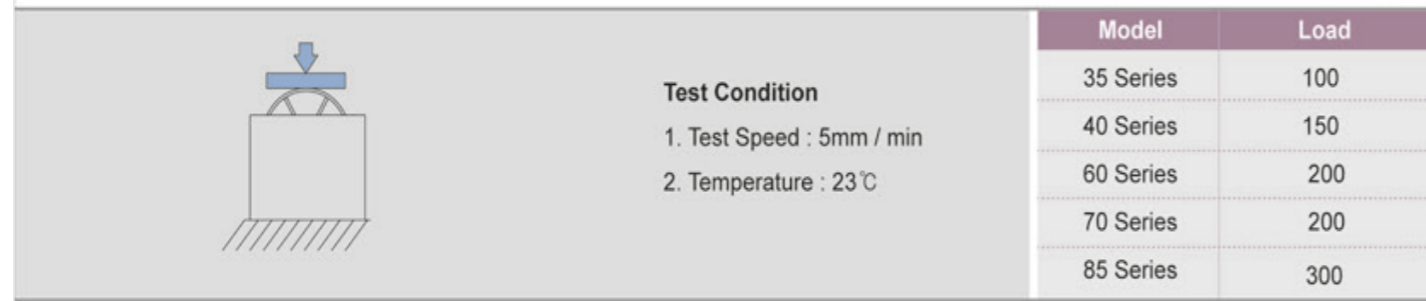

BENDING STRENGTH FOR CONSISTENT

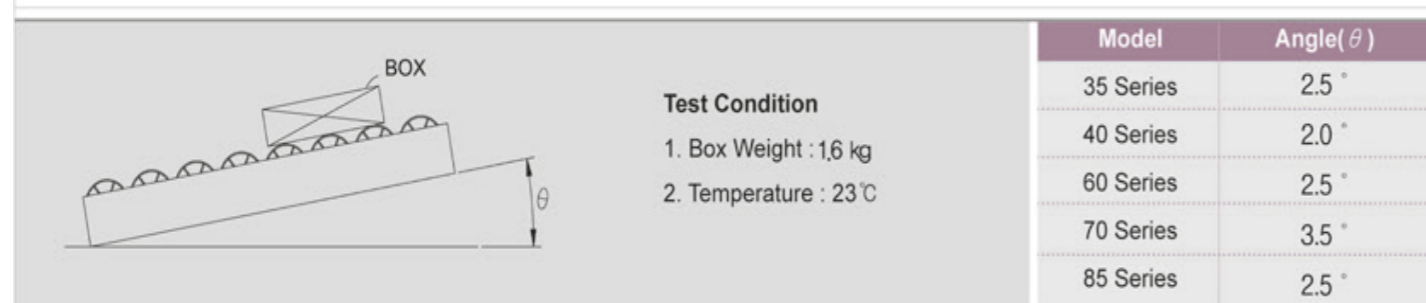

Unit : mm

Series	Part No.	Body Material (mm)	Load Capacity (Kg-f)	Roller Diameter (mm)	Shaft Diameter (mm)	Roller Pitch (mm)	Slope >()°	Roller Color				ESD		Standard Length
								WH	GR	BK	YL	BK	GR	
Silent Roller Track														
25 Series	GPR2528A	AL	60	∅25	∅3	28.57	1.5°	○	○	○	○			4MT
40 Series	GPR4040A	AL (Aluminium)	150	∅34	∅4	40	2.0°	○	○	○	○			4MT
	GPR4040B							○	○	○	○			
	GPR4055C							○	○	○	○			
60 Series	GPR6016S	AL	100	∅15	∅4	16.67	2.5°	○	○	○	○			4MT
	GPR6033B							○	○	○	○			
	GPR6033HA							○	○	○	○			
70 Series	GPR7042B	AL	200	∅34	∅5	42	3.5°	○	○	○	○			4MT
	GPR7042BF							○	○	○	○			
	GPR7021BFS-2							○	○	○	○			
85 Series	GPR8523S	AL	200	∅20.5	∅3.5	22.5	1.5°	○	○	○	○			4MT
	GPR8545B							○	○	○	○			
	GPR8545HA		300	∅40	∅3.5	45		○	○	○	○			
	GPR8545SR							○	○	○	○		2MT	

Standard Roller Track

35 Series	GP3533B	SPCC	100	∅28	∅3	33.33	2.5°	○	○	○	○	○		
40 Series	GP4036A	SPCC (Galvanized Steel Chrome Free)	150	∅34	∅4	36	2.0°	○	○	○	○	○		4MT
	GP4036B							○	○	○	○			
	GP4040A							○	○	○	○			
	GP4040B							○	○	○	○			
	GP4050C							○	○	○	○			
	GP4050D							○	○	○	○			
GP4025M	○	○	○	○										
60 Series	GP6016S	SPCC	100	∅15	∅4	16.67	2.5°	○	○	○	○		4MT	
	GP6033B							150	∅30	33.33	○	○		○
	GP6033HA		○	○	○	○								
70 Series	GP7050BF	SPCC	200	∅34	∅5	50	3.5°			○	○		4MT	
85 Series	GP8525M	SPCC	300	∅34	∅5	25	2.5°	○	○	○	○		4MT	
	GP8543B							○	○	○	○			
	GP8550SR							○	○	○	○			2MT

Curve Roller

40 Series	CR40A	SPCC (Galvanized Steel Chrome Free)	100	∅34	∅4	76	2.0°	○	○	○	○		-
	CR40B							○	○	○	○		
	CR40D							○	○	○	○		

Universal Roller Track

40 Series	UR4050	AL	100	∅43	∅4	50	2.5°		○		○		3MT
60 Series	UR6067		200	∅60	∅5	66.7	3.0°		○		○		2MT

Unit : mm

Unit : mm

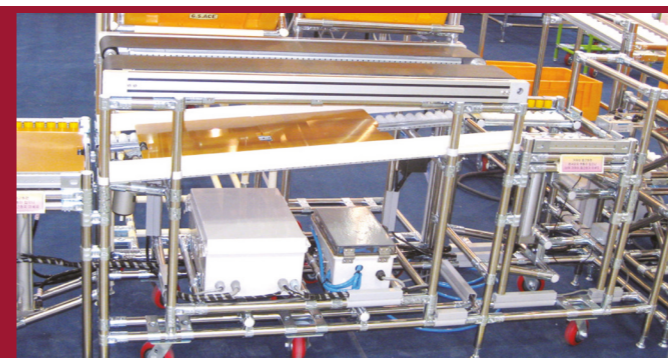
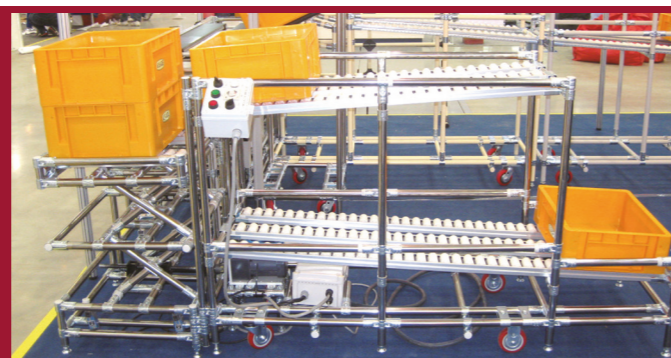
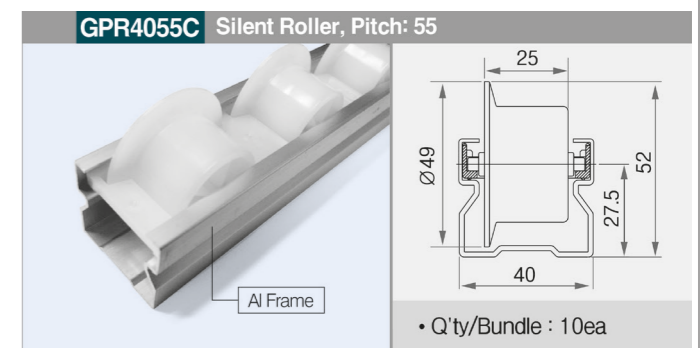
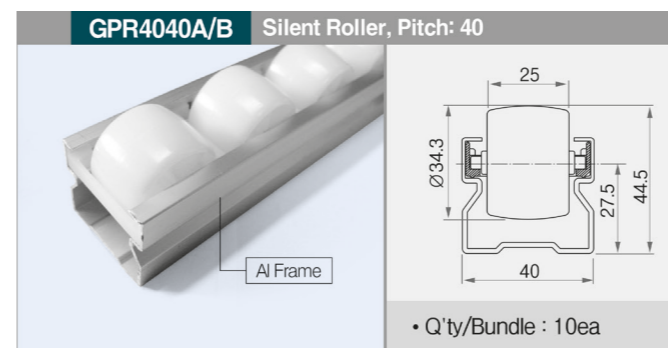
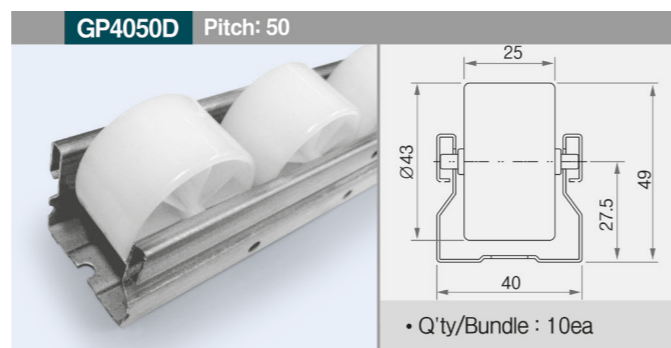
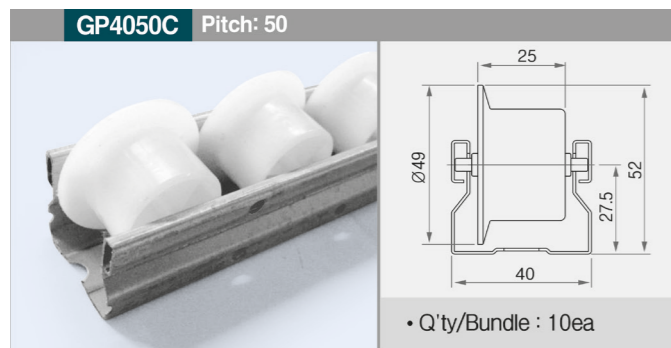
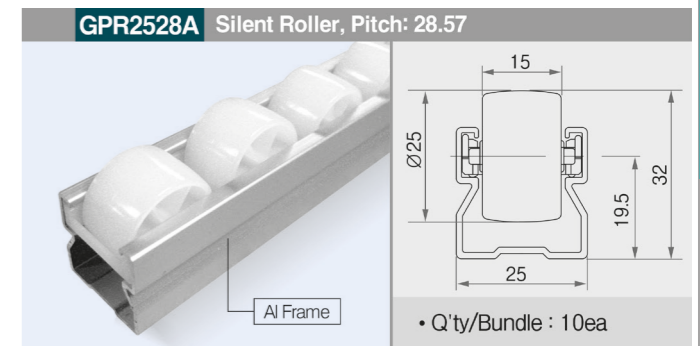
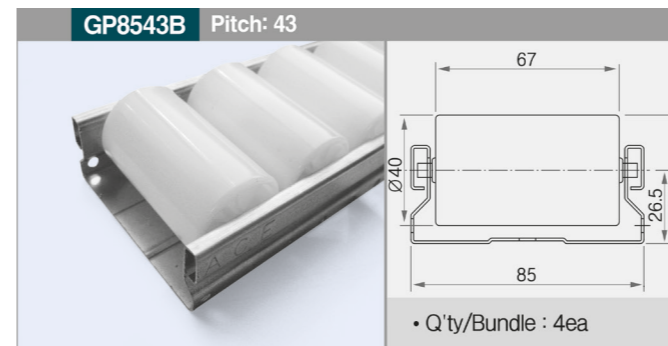
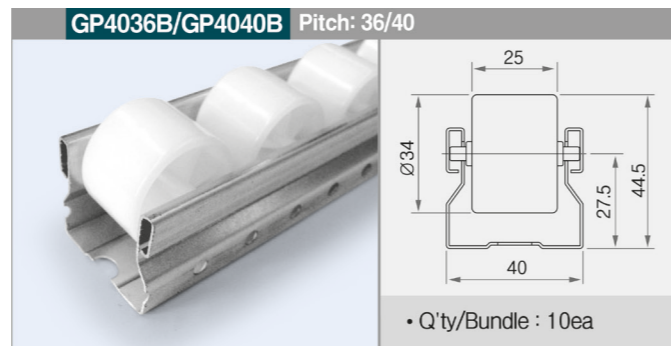
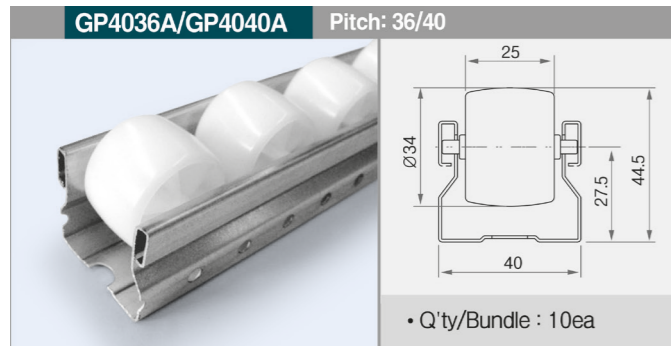
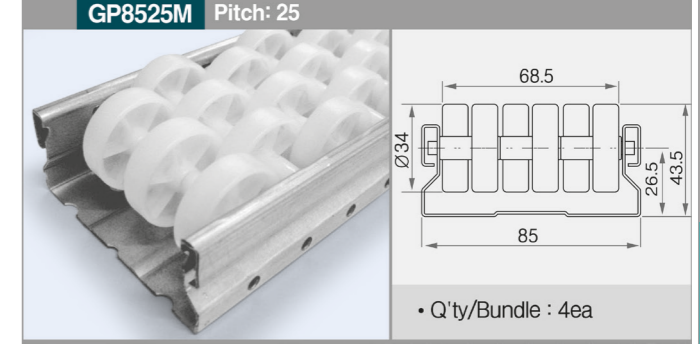
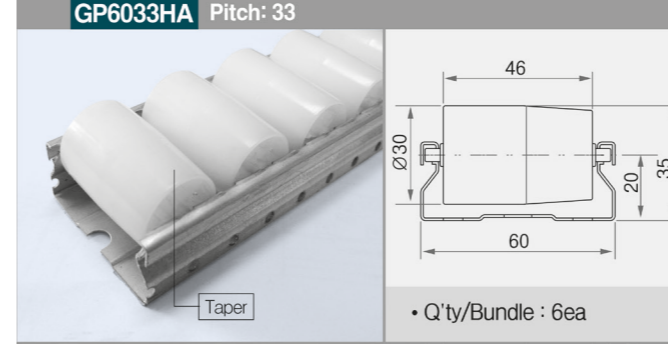
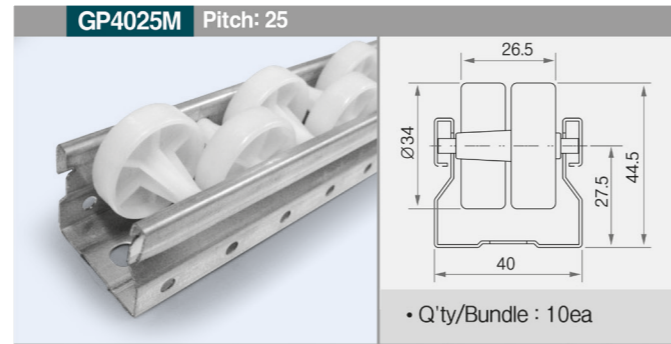
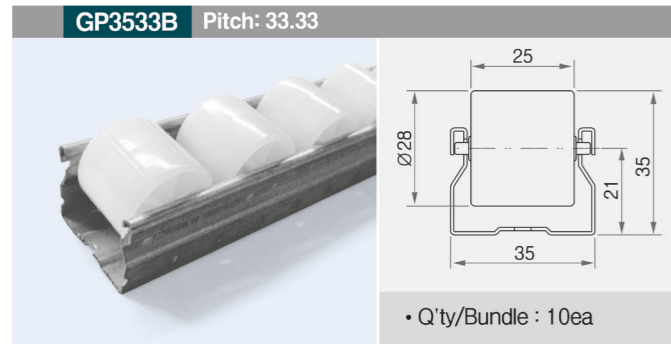
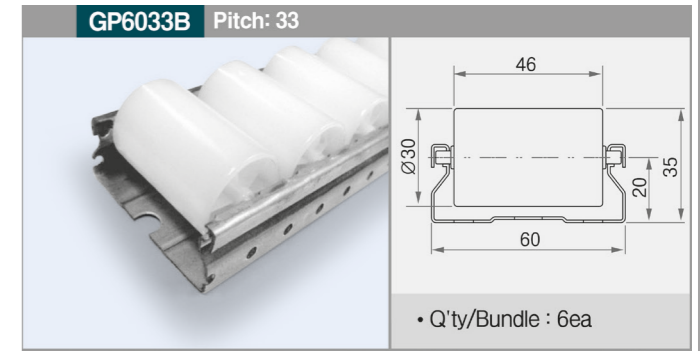
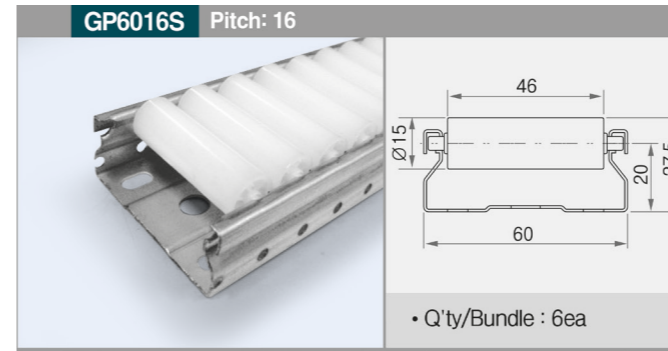
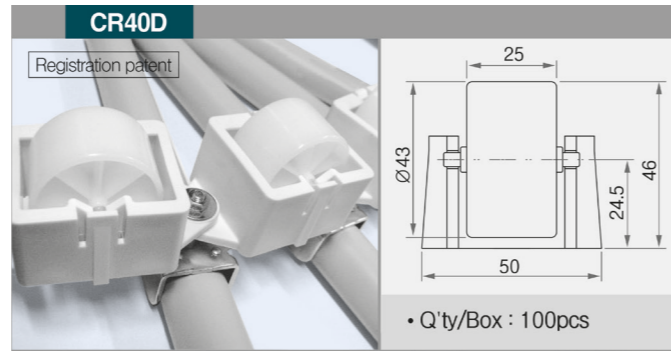
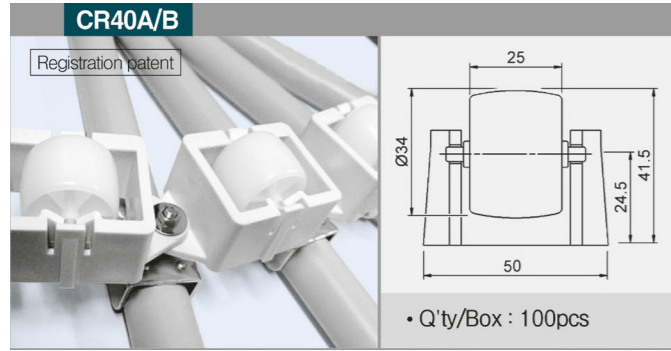

Unit : mm

Unit : mm

GPR6016S Silent Roller, Pitch: 16

Al Frame

• Q'ty/Bundle : 6ea

GPR6033B Silent Roller, Pitch: 33

Al Frame

• Q'ty/Bundle : 6ea

GPR7042B Silent Roller, Pitch: 42

Al Frame

• Q'ty/Bundle : 6ea

GPR7021BFS-2 Silent Roller, Pitch: 21

Al Frame

• Q'ty/Bundle : 6ea

GPR7042BF Silent Roller, Pitch: 42

Al Frame

• Q'ty/Bundle : 6ea

GPR8523S Silent Roller, Pitch: 22.5

Al Frame

• Q'ty/Bundle : 6ea



GPR8545B Silent Roller, Pitch: 45

Al Frame

*Slope: >1.5°

• Q'ty/Bundle : 4ea

GPR8545HA Silent Roller, Pitch: 45

Taper

Al Frame

*Slope: >1.5°

• Q'ty/Bundle : 4ea

GPR8545SR Recycle STS Covered Roller Track, Pitch: 45

STS Cover

PE Roller

AL Frame

*Slope: >1.5°

• Q'ty/Bundle : 4ea

GP8550SR STS Covered Roller, Pitch: 50

STS Cover

PE Roller

SPCC(Gi) Body

• Q'ty/Bundle : 4ea



UR4050 UNIVERSAL Roller, Pitch: 50

Patent Pending

Al Frame

• Q'ty/Bundle : 6ea

UR6067 UNIVERSAL Roller, Pitch: 67

Patent Pending

Al Frame

• Q'ty/Bundle : 4ea

Unit : mm

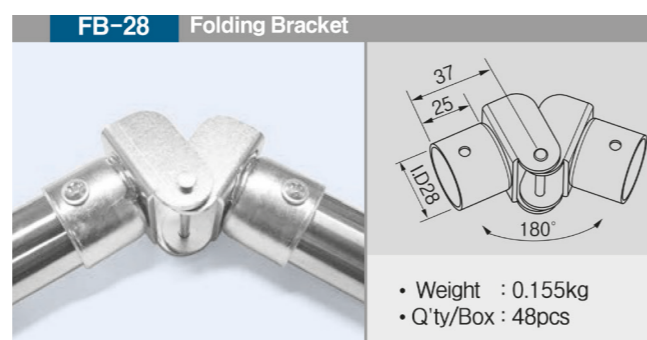
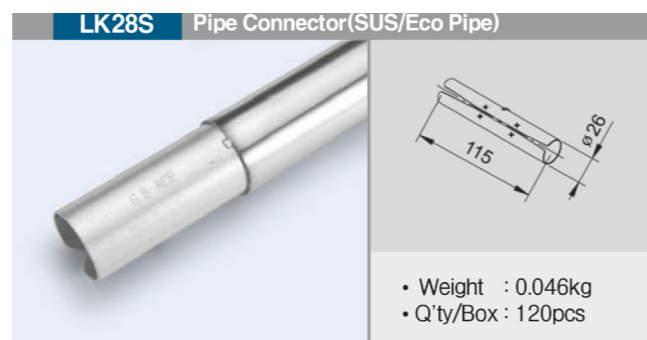
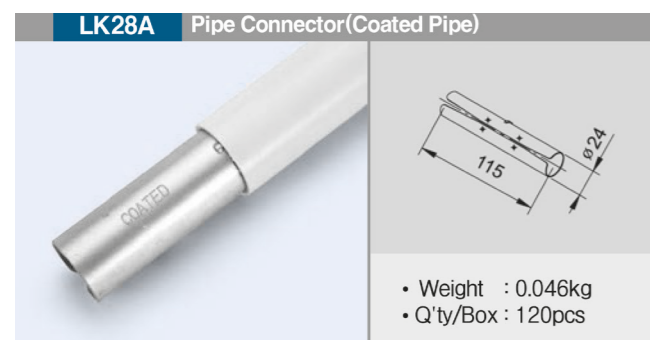
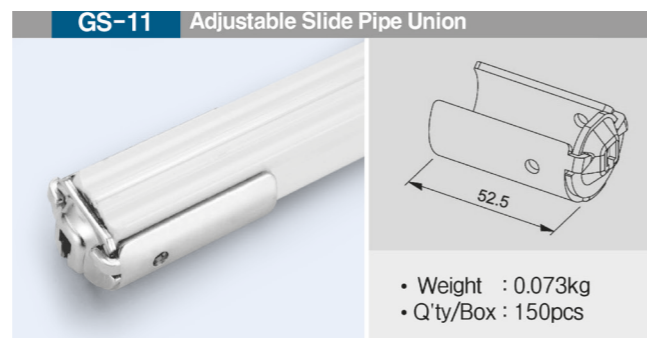
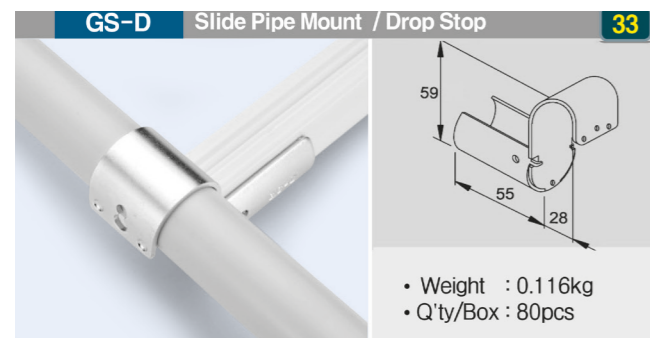
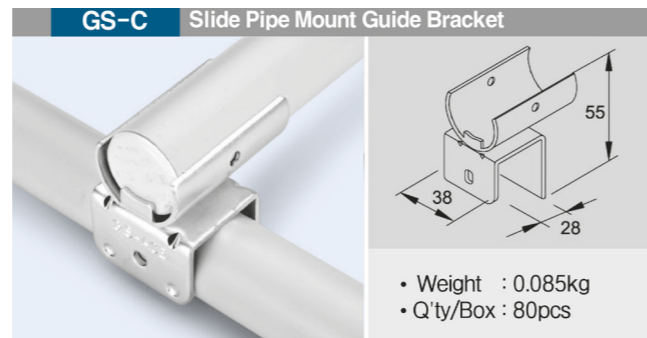
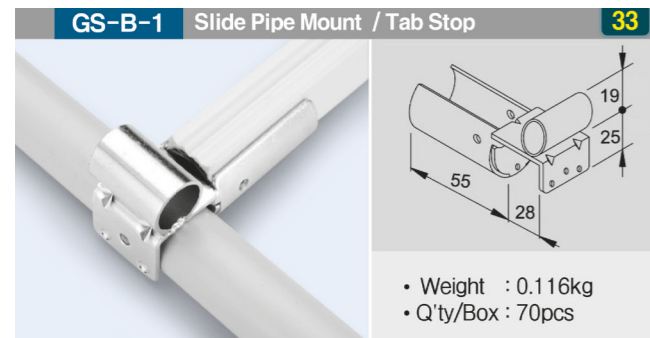
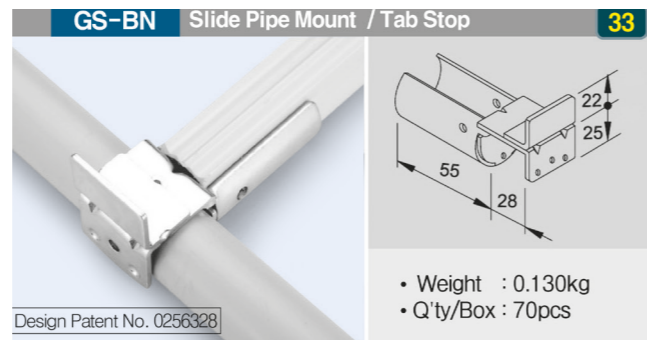
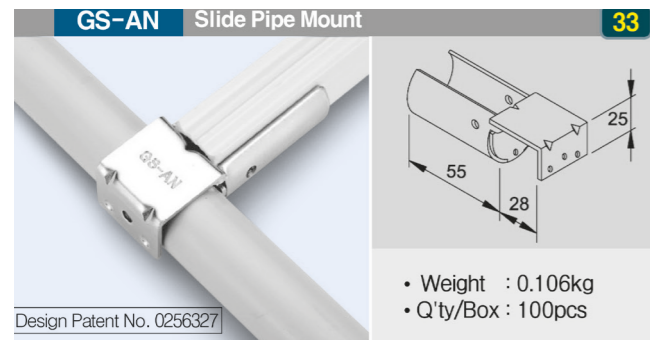

Surface Treatment - WZ

33 is able to be fixed to the joint.
The Part No. of 33 is GP-A33, GP-B33

Unit : mm

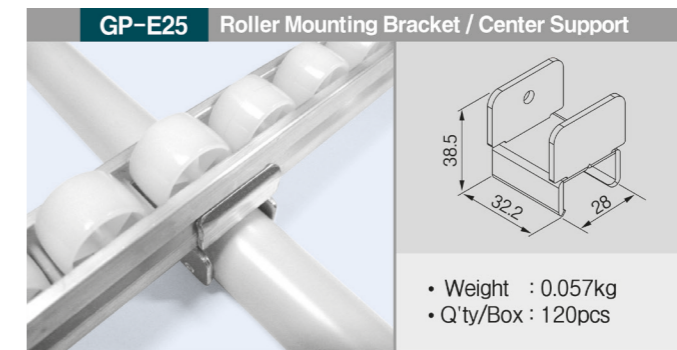
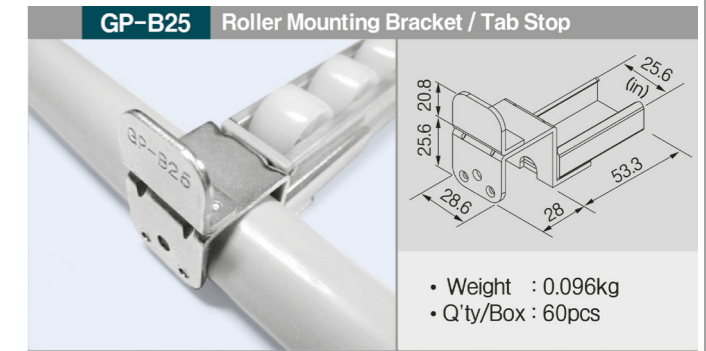
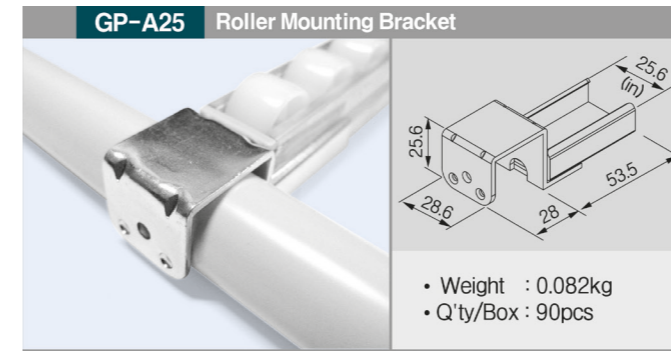

Unit : mm

Unit : mm

GP-A35 Roller Mounting Bracket **33**

Design Patent No. 0256325

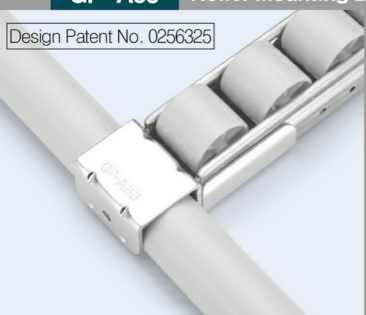
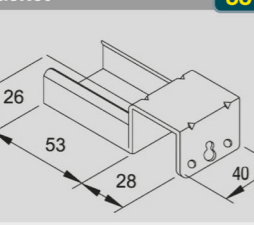
- Weight : 0.111kg
- Q'ty/Box : 80pcs

GP-B35 Roller Mounting Bracket / Tab Stop **33**

Design Patent No. 0256326

- Weight : 0.1326kg
- Q'ty/Box : 60pcs

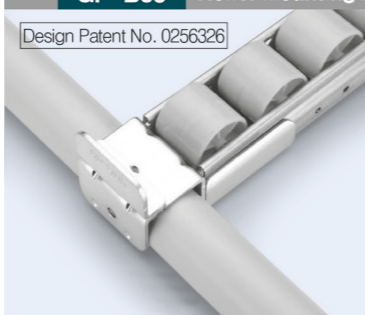
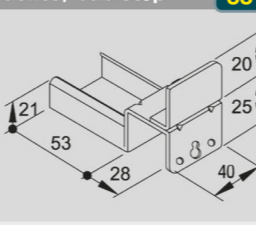
GP-11 Adjustable Roller Union

- Weight : 0.131kg
- Q'ty/Box : 60pcs

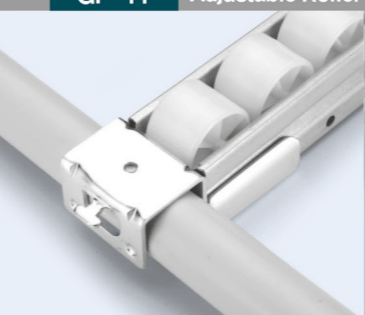
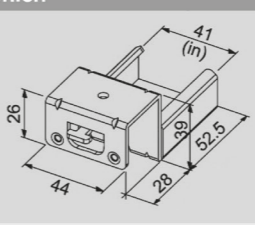
GP-12 Adjustable Roller Union

- Weight : 0.096kg
- Q'ty/Box : 180pcs

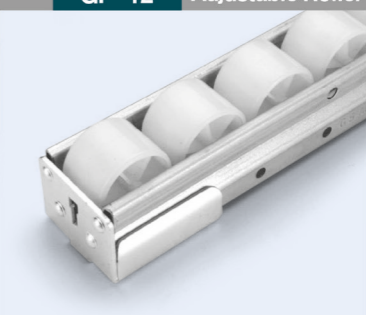
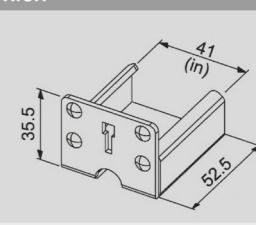
GP-B35-1 Roller Mounting Bracket / Tab Stop

- Weight : 0.240kg
- Q'ty/Box : 70pcs

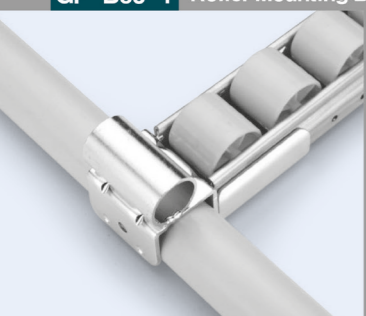
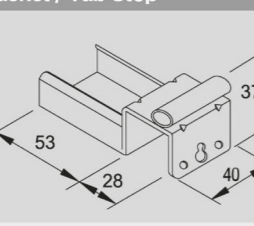
GP-C35 Roller Track Union

- Weight : 0.163kg
- Q'ty/Box : 60pcs

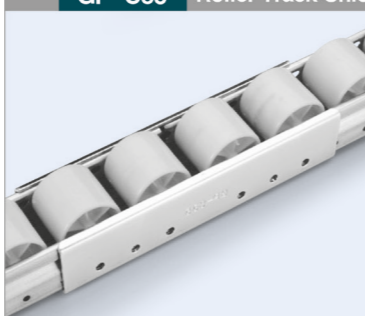
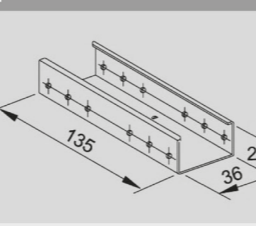
GP-13 Adjustable Roller Union

- Weight : 0.173kg
- Q'ty/Box : 40pcs

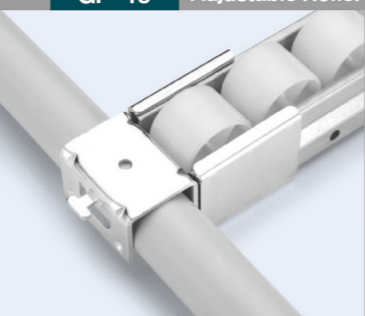
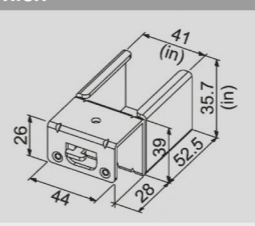
GP-14 Adjustable Roller Union

- Weight : 0.096kg
- Q'ty/Box : 180pcs

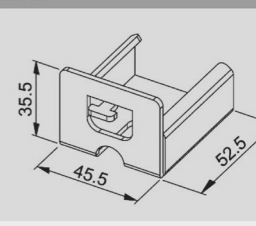
GP-D35 Roller Mounting Bracket / Drop Stop



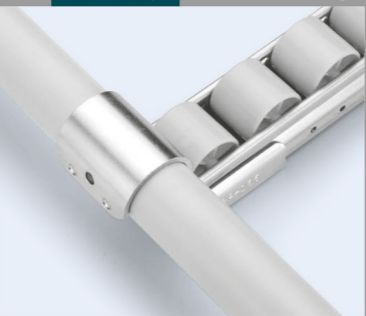
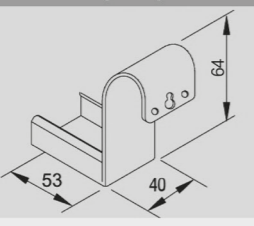

- Weight : 0.129kg
- Q'ty/Box : 70pcs

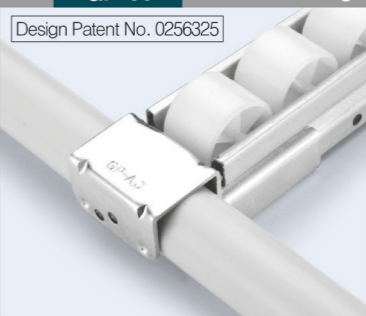
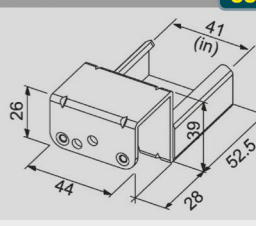

GP-A Roller Mounting Bracket **33**

Design Patent No. 0256325

- Weight : 0.143kg
- Q'ty/Box : 80pcs
- 33** • Q'ty/Box : 60pcs

GP-E35 Roller Mounting Bracket

- Weight : 0.064kg
- Q'ty/Box : 120pcs

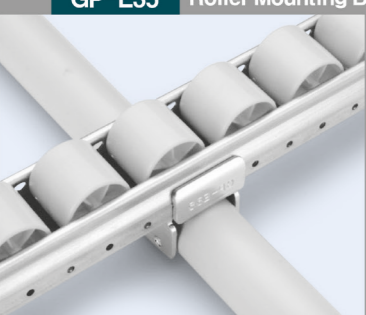
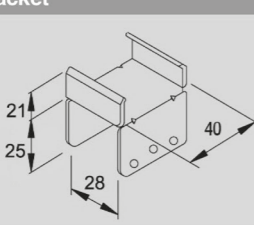
GP-E35-A12 Roller Mounting Bracket

- Weight : 0.120kg
- Q'ty/Box : 60pcs

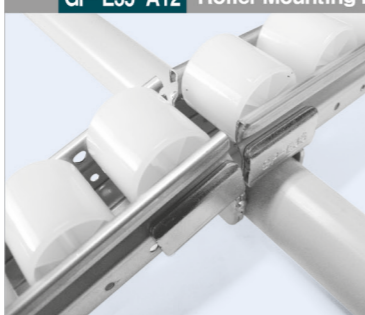
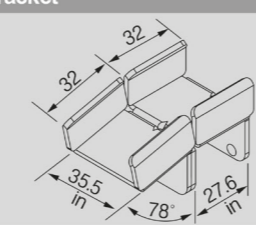
GP-APF-B Roller Mounting Bracket

- Weight : 0.160kg
- Q'ty/Box : 60pcs

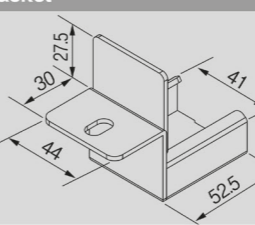
GP-APF Roller Mounting Bracket

- Weight : 0.124kg
- Q'ty/Box : 80pcs

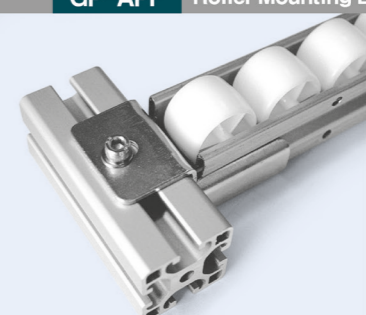
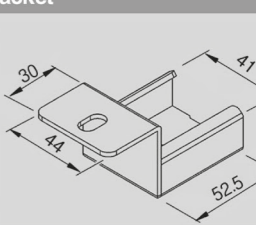
GP-HN35 Roller Track Union

- Weight : 0.175kg
- Q'ty/Box : 36pcs

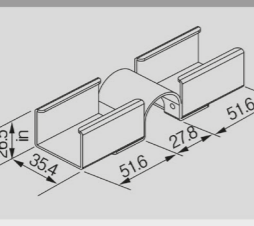
GP-M35 Roller Mounting Bracket

- Weight : 0.210kg
- Q'ty/Box : 30pcs

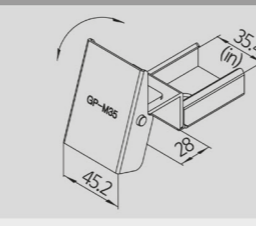
GP-B Roller Mounting Bracket / Tab Stop **33**

Design Patent No. 0256326

- Weight : 0.173kg
- Q'ty/Box : 60pcs
- 33** • Q'ty/Box : 40pcs

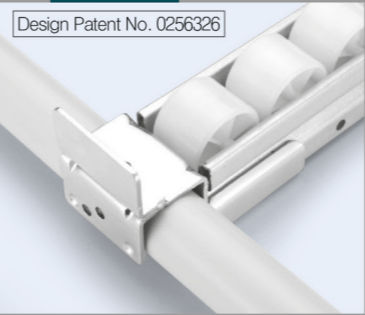
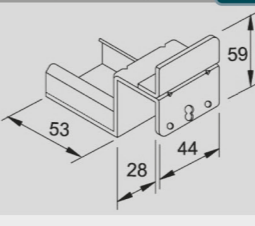
Surface Treatment - WZ

33 is able to be fixed to the joint.
The Part No. of 33 is GP-A33, GP-B33

Unit : mm

GP-B-1 Roller Mounting Bracket / Tab Stop **33**

- Weight : 0.174kg
- Q'ty/Box : 50pcs
- 33** • Q'ty/Box : 40pcs

GP-C Roller Track Union

- Weight : 0.121kg
- Q'ty/Box : 80pcs

GP-F Roller Mounting Bracket **33**

- Weight : 0.175kg
- Q'ty/Box : 50pcs

GP-FA Adjustable Roller to Slide Pipe Union

- GS-11 & GP-13

GP-C-1 Roller Track Union / Center Support **33**

- Weight : 0.170kg
- Q'ty/Box : 40pcs
- 33** • Q'ty/Box : 32pcs

GP-CN Roller Track Union

- Weight : 0.232kg
- Q'ty/Box : 36pcs

GP-FC Roller Mounting Bracket / Tab Stop

- Weight : 0.200kg
- Q'ty/Box : 42pcs

GP-G Roller Mounting Bracket / Tab Stop

- Weight : 0.250kg
- Q'ty/Box : 40pcs

GP-DF Roller Mounting Bracket

- Weight : 0.194kg
- Q'ty/Box : 50pcs

GP-DN Roller Mounting Bracket / Drop Stop **33**

- Weight : 0.165kg
- Q'ty/Box : 70pcs

GP-HF Roller Track Union

- Weight : 0.232kg
- Q'ty/Box : 24pcs

GP-HN Roller Track Union

- Weight : 0.279kg
- Q'ty/Box : 30pcs

GP-EN Roller Mounting Bracket / Center Support

- Weight : 0.217kg
- Q'ty/Box : 20pcs



GP-HP Roller Track Union

- Weight : 0.215kg
- Q'ty/Box : 24pcs

GP-HS Adjustable Roller to Slide Pipe Union

- Weight : 0.200kg
- Q'ty/Box : 20pcs



Unit : mm

GP-J Adjustable Roller to Slide Pipe Union

- GP-11 & GS-11

GP-K Adjustable Roller to Slide Pipe Union

- GP-L & GS-11

GP-L Roller Mounting Bracket **33**

- Weight : 0.144kg
- Q'ty/Box : 70pcs
- 33** • Q'ty/Box : 60pcs

GP-LW Roller Mounting Bracket **33**

- Weight : 0.144kg
- Q'ty/Box : 70pcs
- 33** • Q'ty/Box : 60pcs

GP-LWB Roller Mounting Bracket

- Weight : 0.178kg
- Q'ty/Box : 50pcs

GP-M Roller Mounting Bracket

- Weight : 0.239kg
- Q'ty/Box : 30pcs

GP-NA Roller Mounting Bracket

- Weight : 0.100kg
- Q'ty/Box : 80pcs

GP-NB Roller Mounting Bracket / Tab Stop

- Weight : 0.129kg
- Q'ty/Box : 60pcs

GP-SB Absorber Mounting Bracket

- Weight : 0.107kg
- Q'ty/Box : 70pcs

Surface Treatment - WZ

33 is able to be fixed to the joint.
The Part No. of 33 is GP-A33, GP- B33

Unit : mm

GP-A60 Roller Mounting Bracket **33**

- Weight : 0.164kg
- Q'ty/Box : 60pcs

GP-APF60 Roller Mounting Bracket

- Weight : 0.139kg
- Q'ty/Box : 60pcs

GP-B60-1 Roller Mounting Bracket / Tab Stop

- Weight : 0.196kg
- Q'ty/Box : 30pcs

GP-B60 Roller Mounting Bracket / Tab Stop **33**

- Weight : 0.250kg
- Q'ty/Box : 30pcs

GP-CN60 Roller Track Union

- Weight : 0.168kg
- Q'ty/Box : 68pcs

GP-D60 Roller Mounting Bracket / Drop Stop **33**

- Weight : 0.209kg
- Q'ty/Box : 40pcs

GP-DF60J Roller Mounting Bracket

- Weight : 0.174kg
- Q'ty/Box : 40pcs

GP-E60 Roller Mounting Bracket / Center Support **33**

- Weight : 0.097kg
- Q'ty/Box : 100pcs

GP-EH60 Roller Mounting Bracket / Center Support

- Weight : 0.176kg
- Q'ty/Box : 50pcs

GP-EN60 Roller Track Union / Center Support

- Weight : 0.158kg
- Q'ty/Box : 20pcs

Unit : mm

GP-FC60 Roller Mounting Bracket

- Weight : 0.168kg
- Q'ty/Box : 50pcs

GP-HN60 Roller Track Union

- Weight : 0.254kg
- Q'ty/Box : 35pcs

GP-L60 Roller Mounting Bracket

- Weight : 0.280kg
- Q'ty/Box : 30pcs

GP-L60W Roller Mounting Bracket

- Weight : 0.187kg
- Q'ty/Box : 30pcs

GP-L60WB Roller Mounting Bracket

- Weight : 0.220kg
- Q'ty/Box : 40pcs

GP-M60 Roller Mounting Bracket

- Weight : 0.280kg
- Q'ty/Box : 30pcs

GP-A70 Roller Mounting Bracket **33**

- Weight : 0.204kg
- Q'ty/Box : 50pcs

GP-B70 Roller Mounting Bracket / Tab Stop **33**

- Weight : 0.280kg
- Q'ty/Box : 30pcs

GP-E70 Roller Mounting Bracket / Center Support

- Weight : 0.170kg
- Q'ty/Box : 60pcs

GP-EN70 Roller Mounting Bracket / Center Support

- Weight : 0.265kg
- Q'ty/Box : 12pcs

GP-L70 Roller Mounting Bracket

- Weight : 0.209kg
- Q'ty/Box : 60pcs

GP-M70 Roller Mounting Bracket

- Weight : 0.330kg
- Q'ty/Box : 20pcs



Example for GP-M60

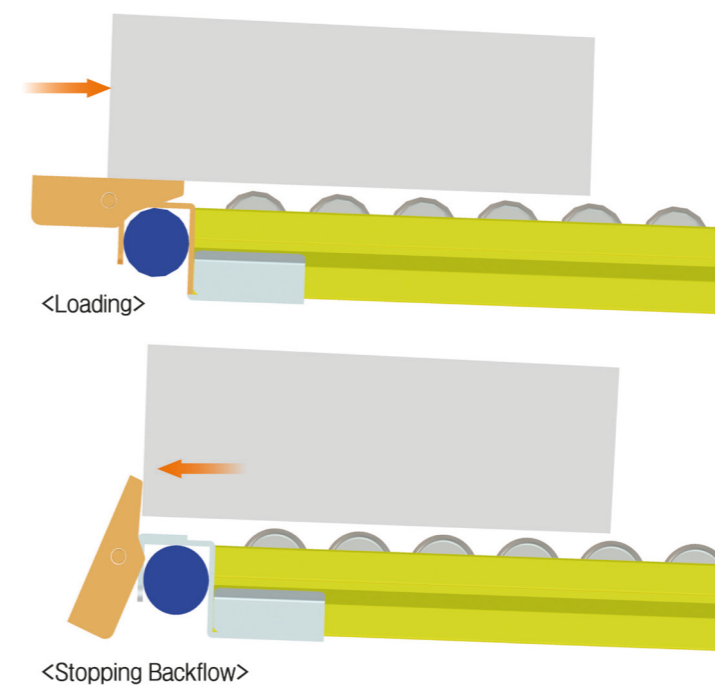

Surface Treatment - WZ
33 is able to be fixed to the joint.
 The Part No. of 33 is GP-A33, GP-B33

Unit : mm

GP-A85 Roller Mounting Bracket 33

- Weight : 0.231kg
- Q'ty/Box : 40pcs

GP-B85 Roller Mounting Bracket / Tab Stop 33

- Weight : 0.300kg
- Q'ty/Box : 30pcs

GP-B85-1 Roller Mounting Bracket / Tab Stop 33

- Weight : 0.318kg
- Q'ty/Box : 20pcs

GP-C85 Roller Track Union

- Weight : 0.140kg
- Q'ty/Box : 70pcs

GP-C85-1 Roller Track Union / Center Support

- Weight : 0.243kg
- Q'ty/Box : 20pcs

GP-D85 Roller Mounting Bracket / Drop Stop

- Weight : 0.235kg
- Q'ty/Box : 30pcs

GP-E85 Roller Mounting Bracket / Center Support 33

- Weight : 0.124kg
- Q'ty/Box : 80pcs

GP-EN85 Roller Mounting Bracket / Center Support

- Weight : 0.324kg
- Q'ty/Box : 12pcs

GP-L85W Roller Mounting Bracket

- Weight : 0.276kg
- Q'ty/Box : 24pcs

GP-M85 Roller Mounting Bracket

- Weight : 0.403kg
- Q'ty/Box : 20pcs

BOX GUIDE PLASTIC

Unit : mm

DP-A Dust Plate

- Weight : 0.36kg/m

RG-40D Box Guide

- Weight : 0.57kg/m

RG-40A Box Guide

- PVC Weight : 0.50kg/m

RG-40C Box Guide

- PVC Weight : 0.70kg/m

RG-40E Box Guide

- Weight : 0.86kg/m

SG-01 Sheet Guide

- Weight : 0.45kg/m

SG-02 Sheet Guide

- Weight : 0.740kg/m

SG-03 Sheet Guide

- Weight : 0.490kg/m

SG-28A(h:30) / SG-2860A(h:60) Box Guide

- Weight : 0.38kg/m



BOX GUIDE ALUMINIUM

Unit : mm

ARG-35B Box Guide- ELF

• Weight : 0.79kg/m

ARG-35C Box Guide- ELF

• Weight : 0.52kg/m

ARG-40A Box Guide- ELF

• Weight : 0.53kg/m

ARG-4030BL(h:30) / ARG4045BL(h:45) Box Guide- ELF

• Weight : 0.87kg/m

ARG-4032AN Box Guide- ELF

• Weight : 0.67kg/m

ARG-40C Box Guide- ELF

• Weight : 0.62kg/m

ARG-40D Box Guide- ELF

• Weight : 0.57kg/m

ARG-40F Box Guide- ELF

• Weight : 1.11kg/m

EWS-() WORK STOPPER

STANDARD TYPE (Material-ST5)



SPECIAL TYPE (Material-ST5)



Part No	Model	Weight	Q'ty/Box
EWS -A	GP4036A/4036B	0.056kg	240pcs
EWS-B	GP4050C	0.041kg	300pcs
EWS-C	GP8550SR	0.136kg	70pcs
EWS-D	GP4050D	0.061 kg	160 pcs
EWS-E	GP3533B	0.036 kg	320 pcs
EWS-F	GP6033B	0.085 kg	170 pcs
EWS-G	GP4040A/B	0.085 kg	240 pcs
EWS-J	GP6016S	0.078 kg	200 pcs
EWS-K	GP8543B/HA	0.140 kg	90 pcs

Part No	Model	Weight	Q'ty/Box
EWS -AN	GP4036A/4036B	0.086kg	250 pcs
EWS-GN	GP4040A/B	0.056kg	250 pcs
EWS-MN	GPR8545B/HA	0.155kg	30pcs

WR-() WIRE RACKS

Part No	Pipe	A	Weight	Q'ty/Box
WR-200		235	0.182	25
WR-300	Ø28	335	0.230	80
WR-400		435	0.271	30



PR-01 Pipe Roller

• Weight : 0.031kg
• Q'ty/Box : 150pcs

SR-40 Stop Roller

• Weight : 0.012kg
• Q'ty/Box : 450pcs

DR-40R Decelerating Roller

• Weight : 0.035kg
• Q'ty/Box : 120pcs

Roller Q'ty	Maximum Box Brake Weight Per Slope					Remark
	$\theta = 1.5^\circ$	$\theta = 2.0^\circ$	$\theta = 2.5^\circ$	$\theta = 3.0^\circ$	$\theta = 3.5^\circ$	
1set(2ea)	32Kg	25Kg	6 Kg	4 Kg	2.5 Kg	Roller Load =1.4Kgf/ea
2set(4ea)	-	32Kg	12Kg	9 Kg	5 Kg	



CASTERS

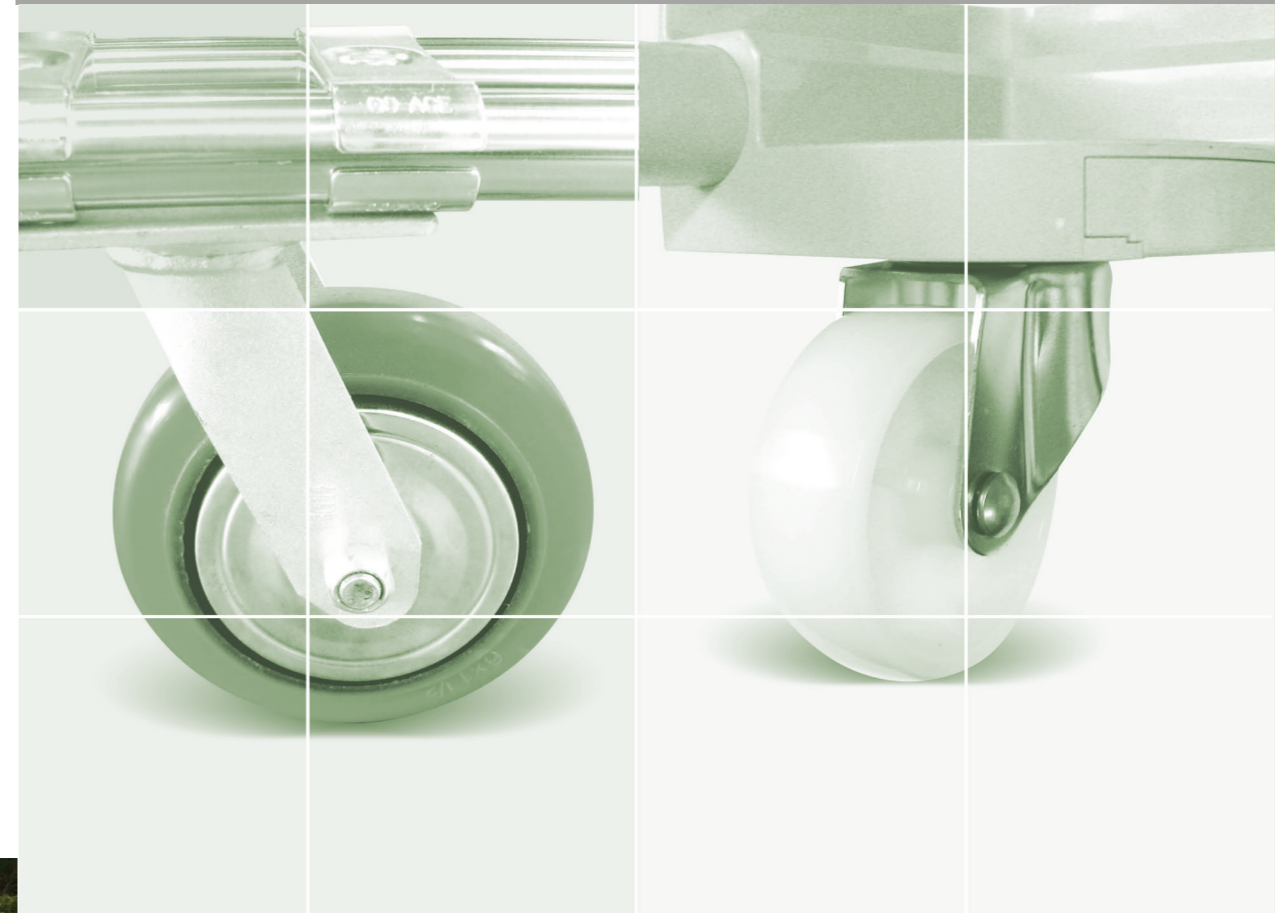

KH-200-Adjustment

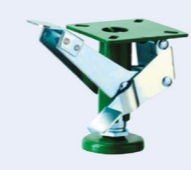

KH200-6

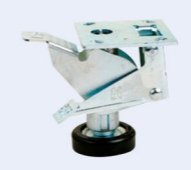





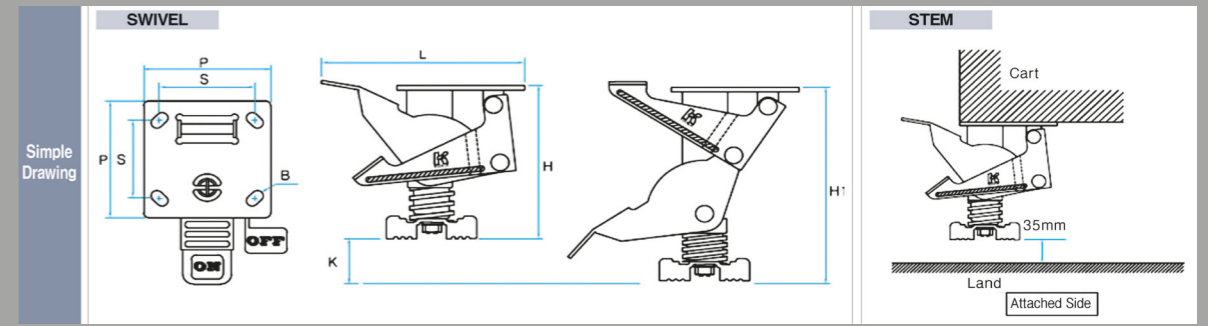

KH200-8



Item No.	H	K	H1	L	P	S	B	Caster Height
125-140KH-200-4	103	27	130-145	150	97X88	70X60	10	125-140
KH-200-Stainless	165	45	210-230	191	120X120	85X85	10	190-220
KH-200-Adjustment	165	45	210-230	191	120X120	85X85	10	190-220
KH-200-6	157	45	198	191	120X120	85X85	11	190-195
KH-200-8	212	45	257	191	120X120	85X85	11	241-250



						
Référence	961776	961267	959219	902261	903172	903196
Color	Blue	Blue	Blue	Blue	Yellow	Yellow
Ø roue (mm)	125	100	125	125	160	160
Largeur bandage (mm)	40	34	40	40	50	50
Dimension de platine (mm)	-	-	105 x 85	103 x 85	137 x 105	137 x 115
Distance entre axe (mm)	-	-	80/77 x 60	80/77 x 60	105 x 80/75	105 x 80/75
Diamètre des trous (mm)	-	-	9	9	11	11
Déport (mm)	40	41	40	-	60	-
Diamètre d'encombrement (mm)	205	233	233	-	334	-
Hauteur (mm)	155	128	155	155	200	200
Résistance à la température (C°)	-20° à +80°			-20° à +60°		
Norme	EN 12532			EN 12532		
Poids (kg)	0,75	0,81	1,246	0,812	2,823	2,081
Rayon d'encombrement	102,5	116,5	116,5	-	167	-
Dureté du bandage (Shore)	64 A	64 A	64 A	64 A	92 A	92 A
Capacité en charge dynamique (kg)	125	125	125	250	350	350
Capacité charge statique	250	250	250	500	700	700
Trou central (mm)	13	13	-	-	-	-
Resistance au roulement	-	-	3/5	3/5	3/5	3/5
Bruit du mouvement	-	-	5/5	5/5	3/5	3/5
Usure	-	-	3/5	3/5	4/5	4/5
Resistance à l'oxydation	-	-	3/5	3/5	3/5	3/5
Roulette	Pivotante		Pivotante à blocage total suiveur	fixe	Pivotante à blocage total suiveur	fixe
Chape	acier embouti					
Finition	zingué		zingué blue	zingué	zingué blue	
Pivot	double chemin de billes		-	dbl chem.billes	-	
Axe de roue	boulonné					
Fixation	à l'œil	trou central	platine		platine	
Corps de roue	Polyamide				aluminium	
Bandage	caoutchouc élastique non tachant				polyuréthane coulé	
Roulement	rouleaux				à billes de précision	

CASTER INSERT

REF 903953 - Ø21,5 - 24



H07-Ø21,5-24
EAN 4031582321388

Fixation expansible pour tubes ronds

Fiche technique

Diamètre de l'expansible	21,5 - 24 mm
Résistance à la température	- 10 / + 40 °C
Poids	0.126 kg

Résistance au roulement	+	+	+	+	+
Bruit du mouvement	+	+	+	+	+
Usure	+	+	+	+	+
Résistance à l'oxydation.	+	+	+	+	+



Unit : mm

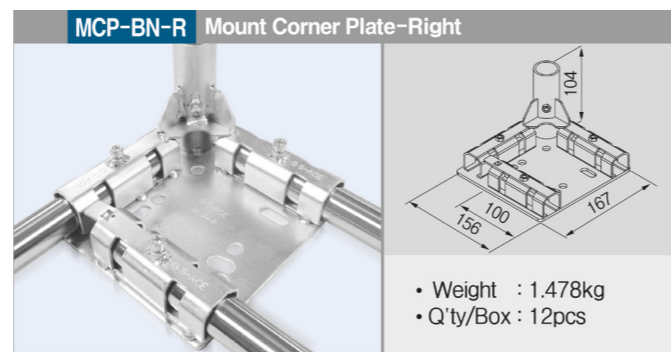
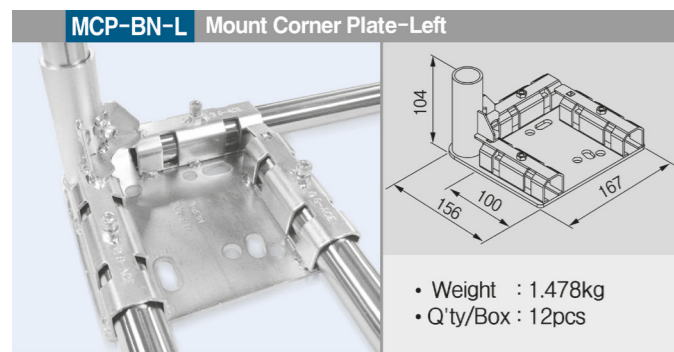
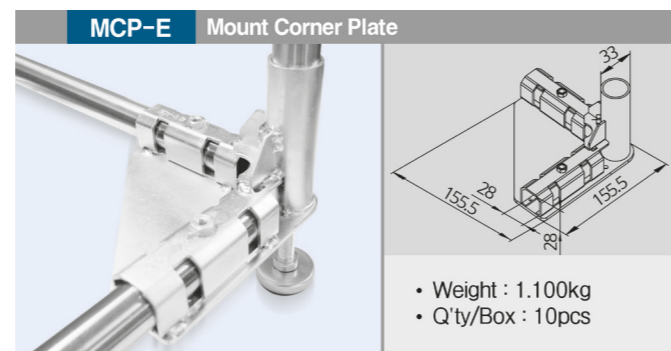
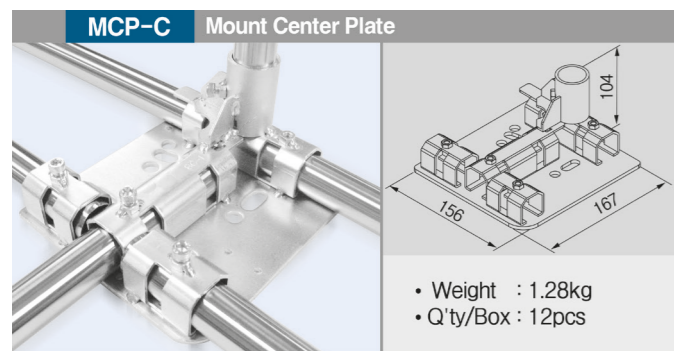
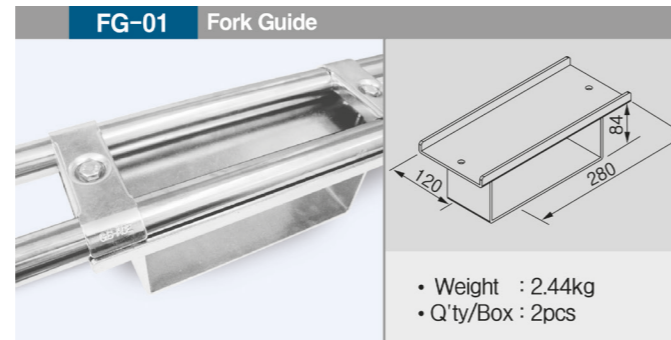
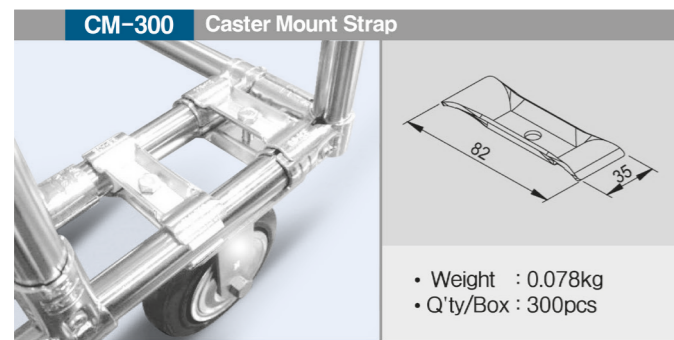
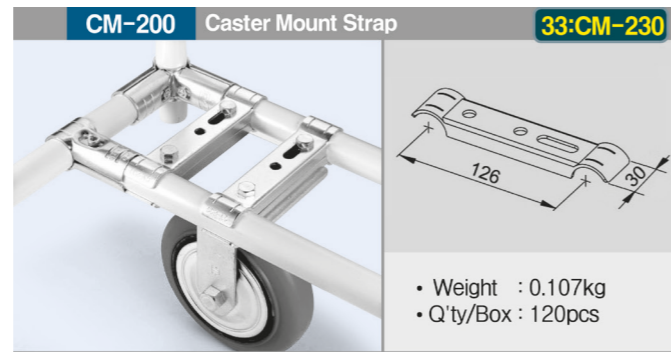
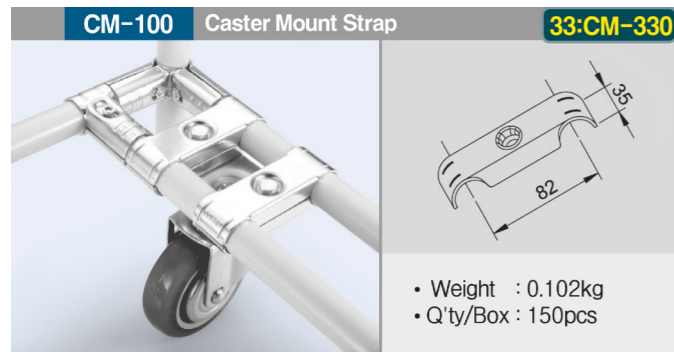

SQUARE PIPE BASE

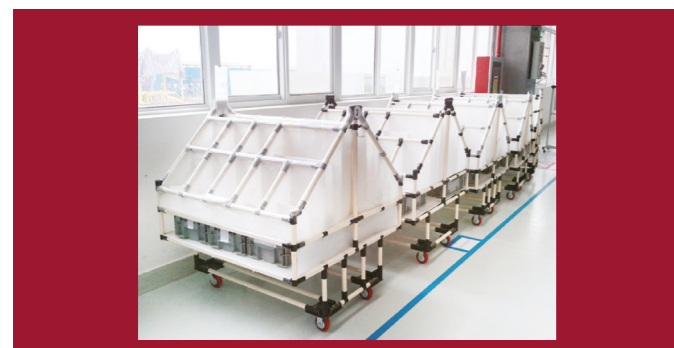
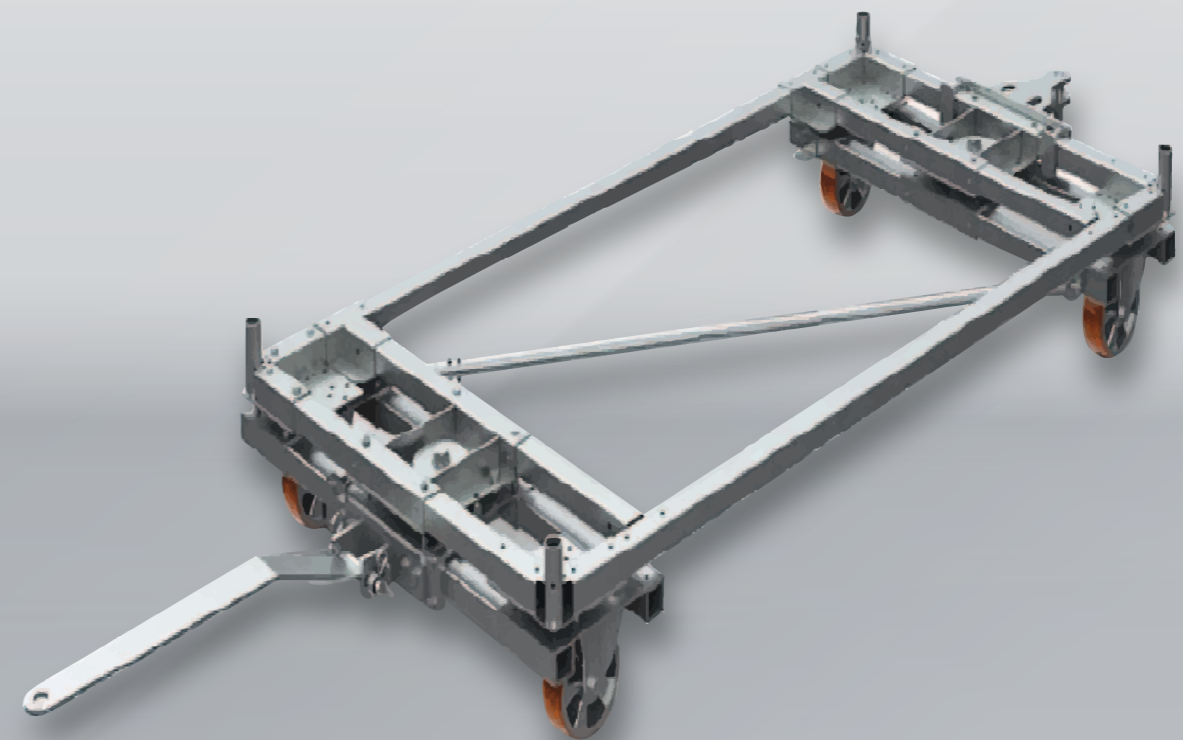

Surface Treatment - WZ

33 is able to be fixed to the joint.
The Part No. of 33 is GP-A33, GP-B33

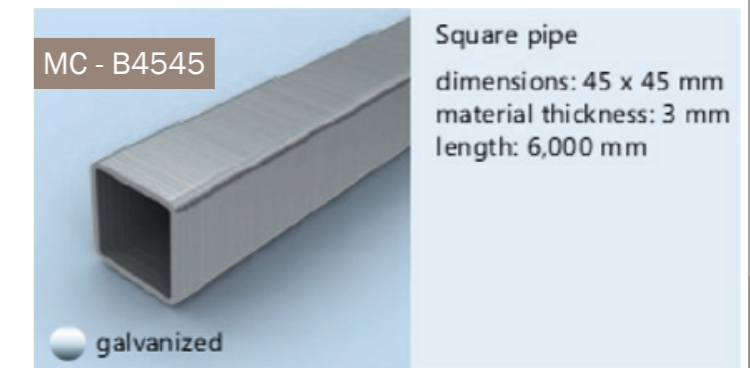
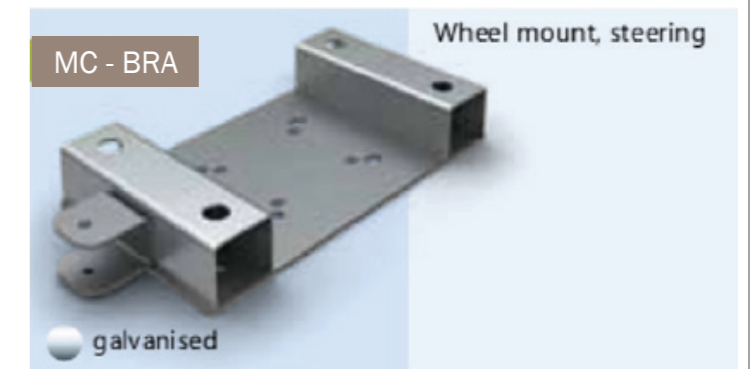
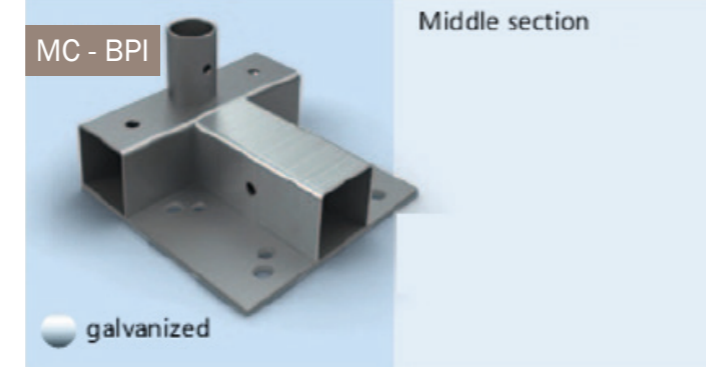
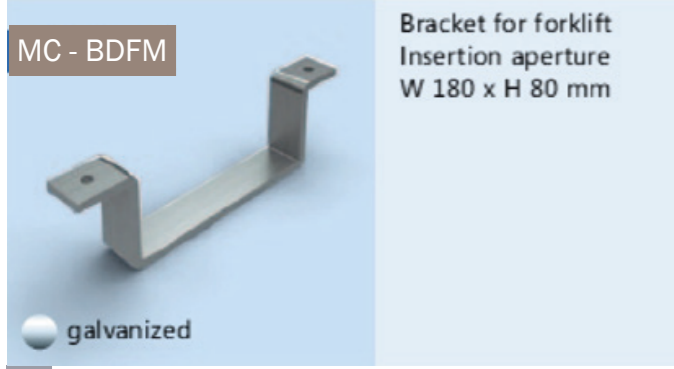
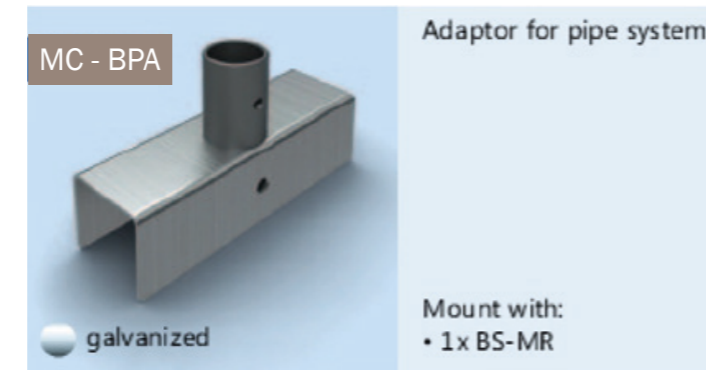
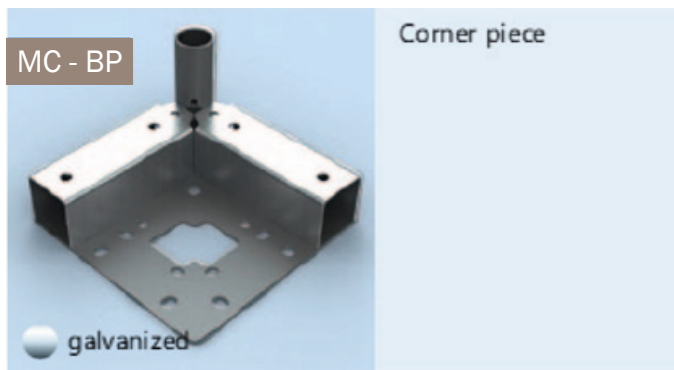
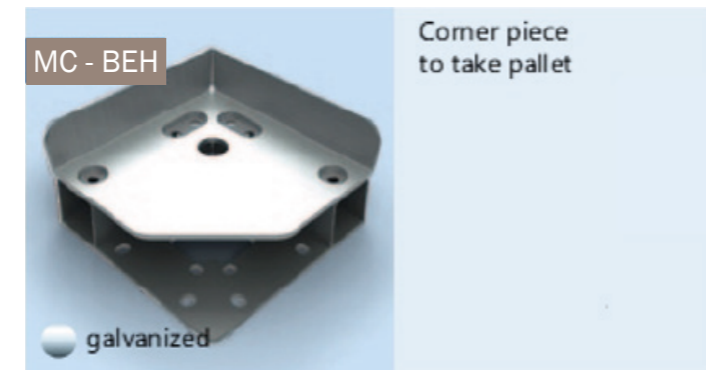
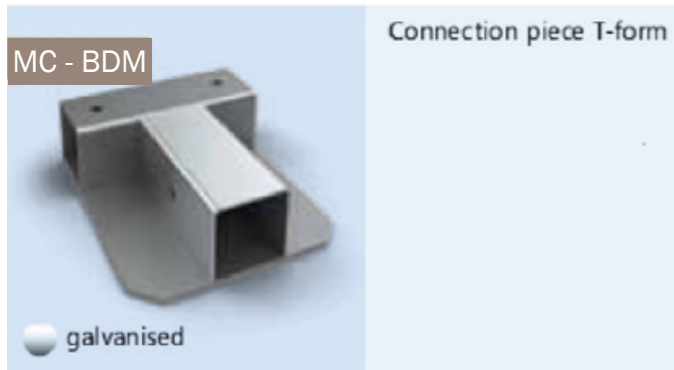
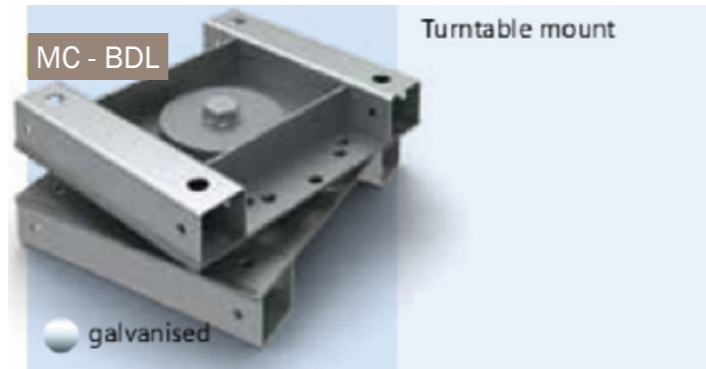
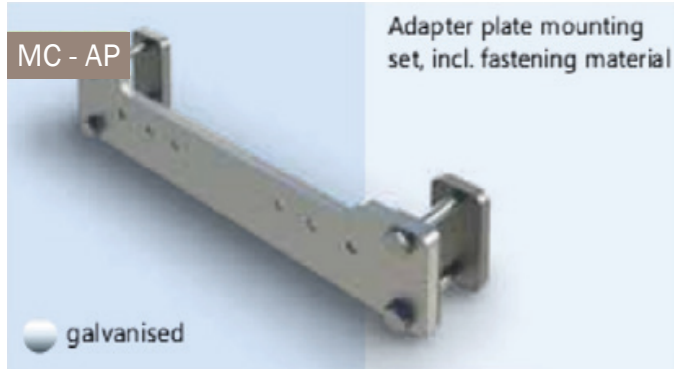

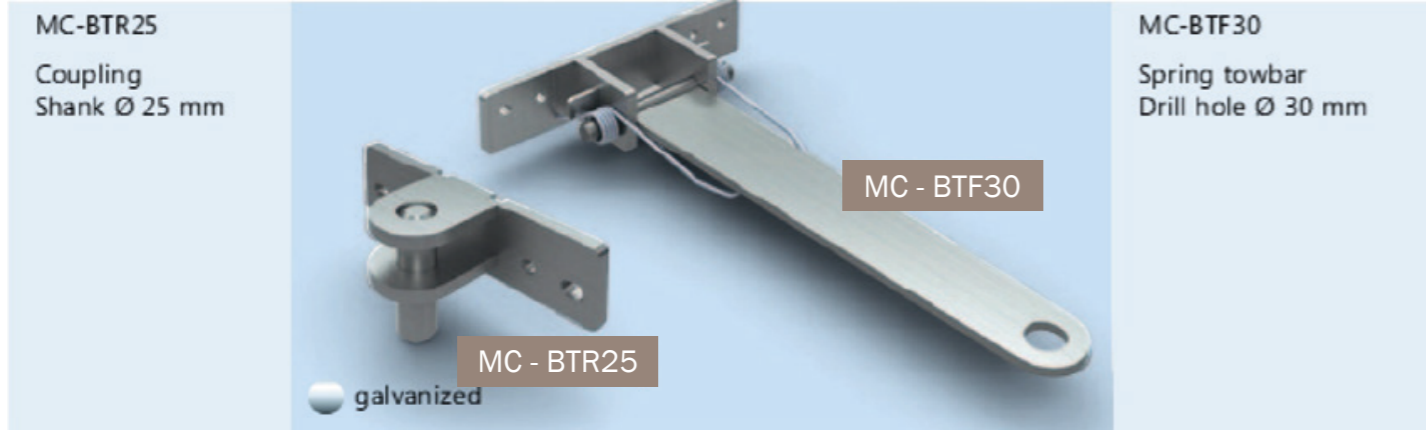

Towing bars and couplings

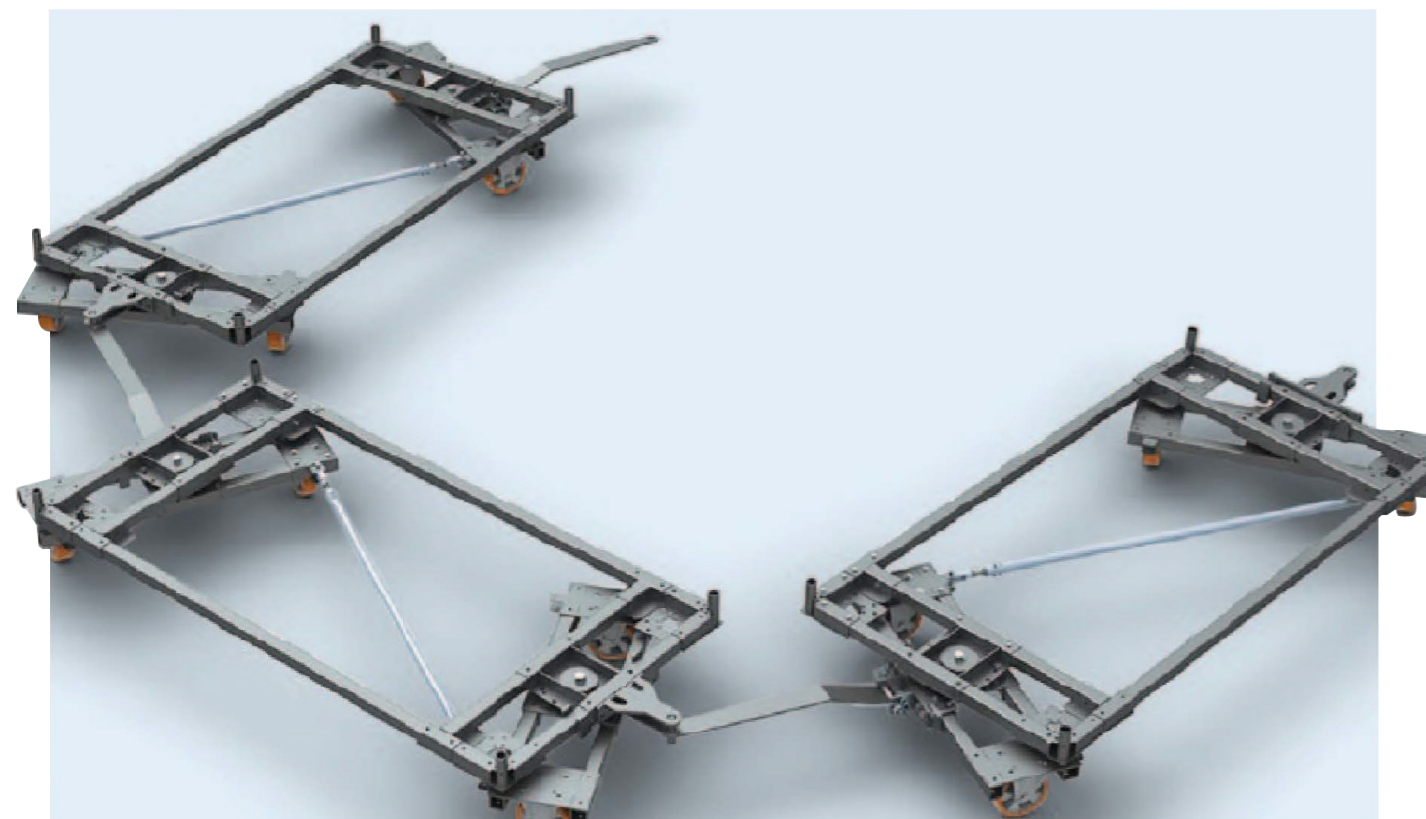
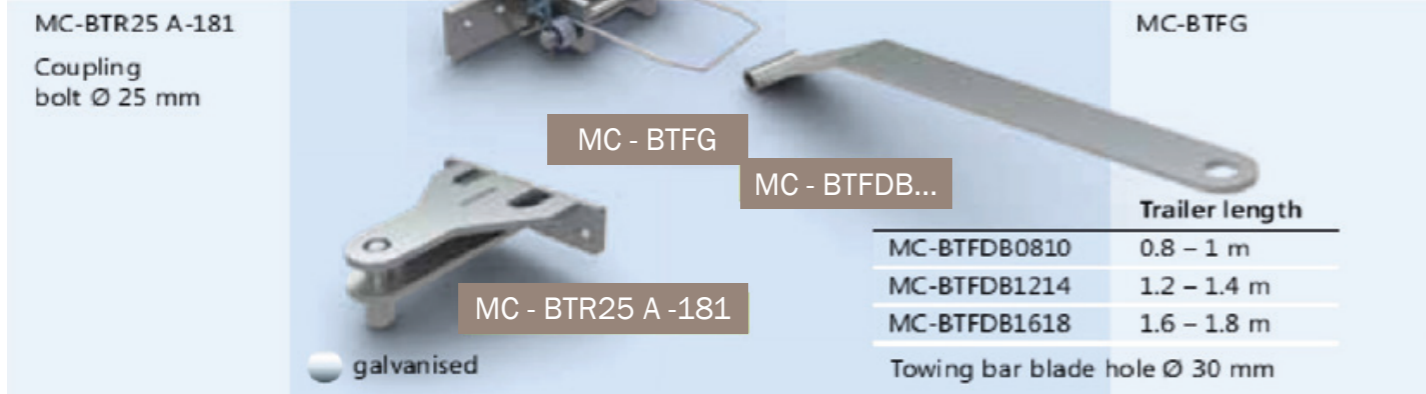

ACCESSORIES

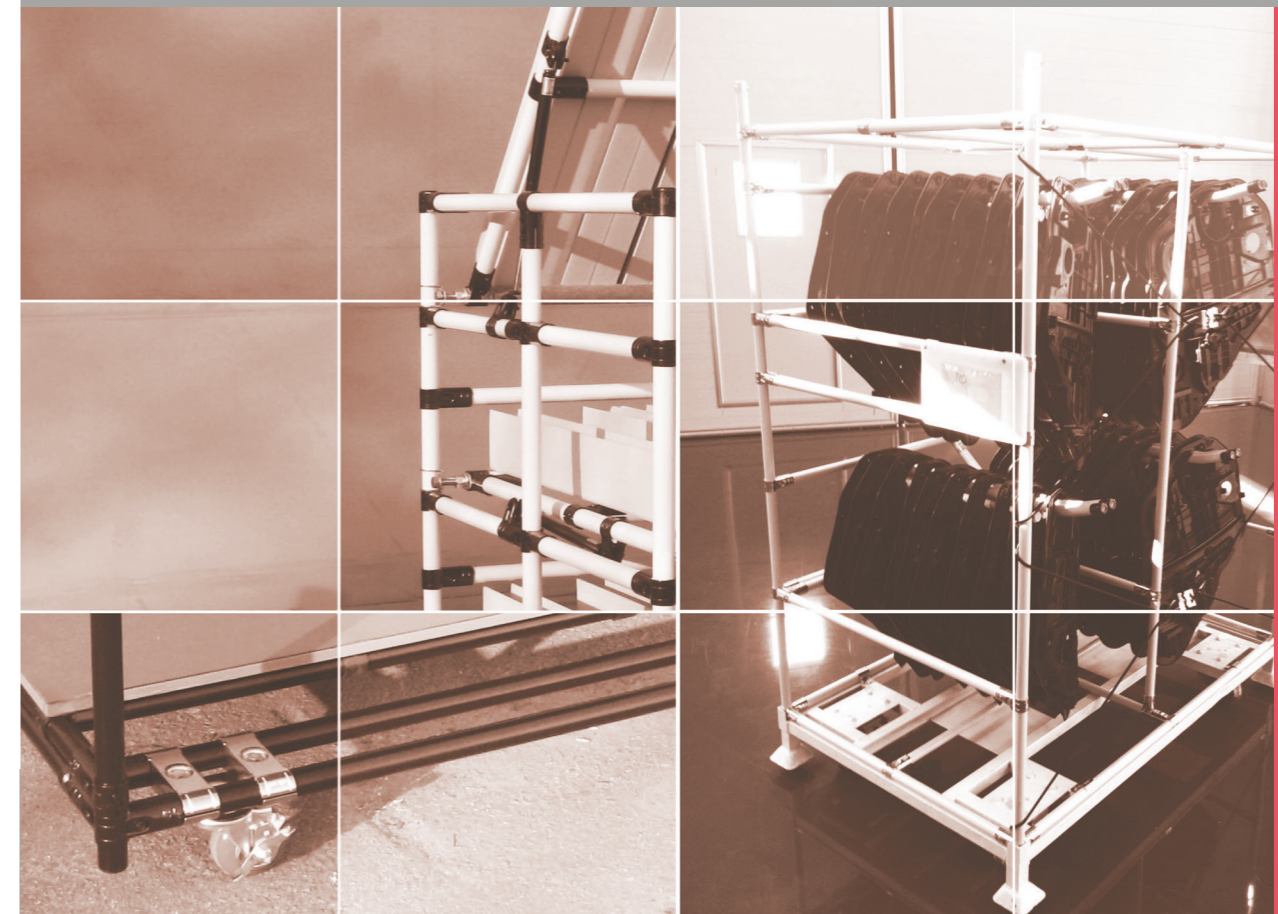

PLASTIC COLORS

- Ivoire
- Gray
- Green
- Black (ESD)
- Dark gray

MENU

Plastic accessories

Accessories 76
Separators / Clamps 77

Aluminium accessories 78 - 84

Tiles holder

Metal holder 85
Plastic & Struts 86

Identification 87 - 88

Caps

pipe caps 89 - 91
safety caps 91
roller track caps 92

Inserts 93 - 94

Legs 95 - 96

Screws 97

Security 98

Others 99 - 107

Unit : mm

L-Type

Part No		Thickness	H	W	Configuration
Normal	ESD				
AL-1	EAL-1	3	30	50	
AL-2	EAL-2	4	30	60	
AL-9	EAL-9	4	30	75	
AL-5B	EAL-5B	4	50	50	
AL-6B	EAL-6B	4	50	75	
AL-8	EAL-8	4	50	100	
AL-7B	EAL-7B	4	50	150	
AL-4	EAL-4	4	80	90	
AL-5	EAL-5	5	50	50	
AL-6	EAL-6	5	50	75	
AL-7	EAL-7	5	50	150	

T-Type

Part No		Thickness	H	W	Configuration
Normal	ESD				
AT-1	EAT-1	4	50	100	
AT-2	EAT-2	4	100	60	
AT-3	EAT-3	4	150	60	

U-Type

Part No		Thickness	W1	W2	H1	H2	Configuration
Normal	ESD						
AU-1	EAU-1	3	36	-	36	36	
AU-2	EAU-2	3	60	-	30	40	

S-Type

Part No		Thickness	W1	W2	H1	H2	Configuration
Normal	ESD						
AS-1	EAS-1	4	32	70	34	25	
AS-2	EAS-2	5	22	60	30	30	
AS-3	EAS-3	4	17	50	30	30	

Pipe-Cover

Part No		Thickness	θ	-	-	-	Configuration
Normal	ESD						
PC-01	EPC-01	2.5	75°	-	-	-	
PC-02	EPC-02	2.5	135°	-	-	-	

Unit : mm

SEPARATEUR

GAP-19 Plastic Joint

- Weight : 0.009kg
- Q'ty/Box : 750pcs

GAP-34 Plastic Joint

- Weight : 0.014kg
- Q'ty/Box : 500pcs

GAP-39 Plastic Joint

- Weight : 0.047kg
- Q'ty/Box : 160pcs

GAP-54 Plastic Joint

- Weight : 0.025kg
- Q'ty/Box : 150pcs

GAP-61 Plastic Joint

- Weight : 0.015kg
- Q'ty/Box : 500pcs

COLLIER

GAP-23 Plastic Joint

Include Bolt & Nut

- Weight : 0.020kg
- Q'ty/Box : 1500pcs



GAP-37A Plastic Joint

Sold separately Bolt & Nut

- Weight : 0.011kg
- Q'ty/Box : 600pcs

GAP-37B Plastic Joint

Sold separately Bolt & Nut

- Weight : 0.019kg
- Q'ty/Box : 300pcs

Unit : mm

Unit : mm

ABS-620 Board Support



- Weight : 0.020kg
- Q'ty/Box : 300pcs
- ABS-600SA Standard Length: 4MT

*Application Example: Reference page 89

ABS-4320A Board Support

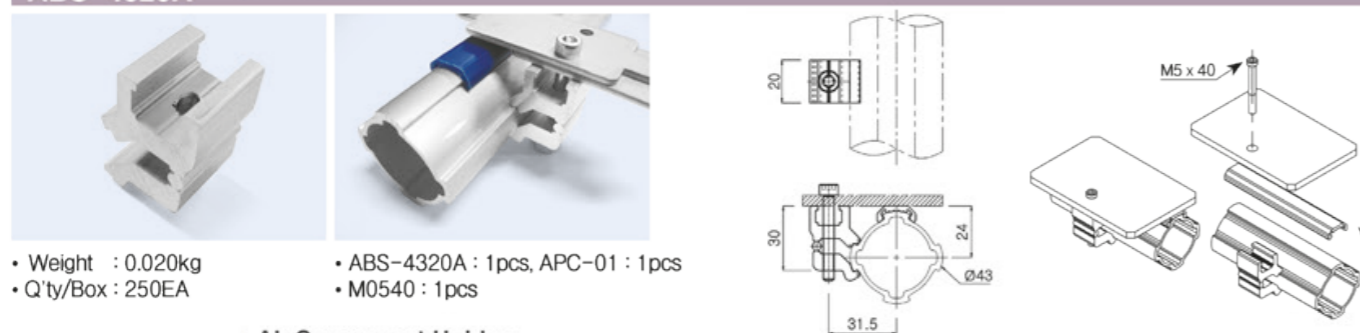

- Weight : 0.020kg
- Q'ty/Box : 250EA
- ABS-4320A : 1pcs, APC-01 : 1pcs
- M0540 : 1pcs

ACH-6040A AL Component Holder

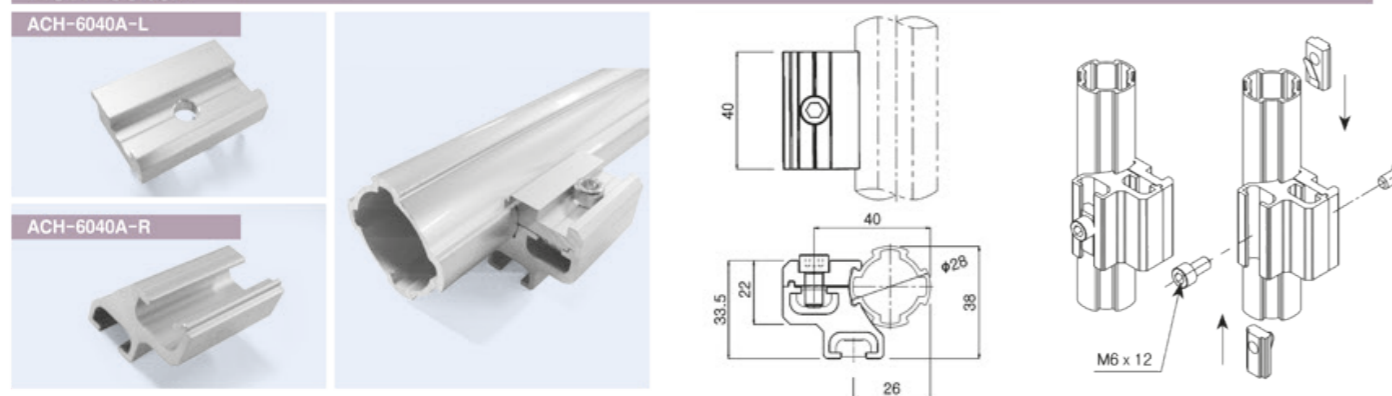

- ACH-6040A-L
- ACH-6040A-R
- Weight : 0.017kg
- Weight : 0.033kg
- Q'ty/Box : 400EA
- Q'ty/Box : 150EA
- ACH-6040A-R : 1pcs, ACH-6040A-L : 1pcs
- M0612 : 1pcs, SN406 : 1pcs

ACM-500 AL Caster Mount

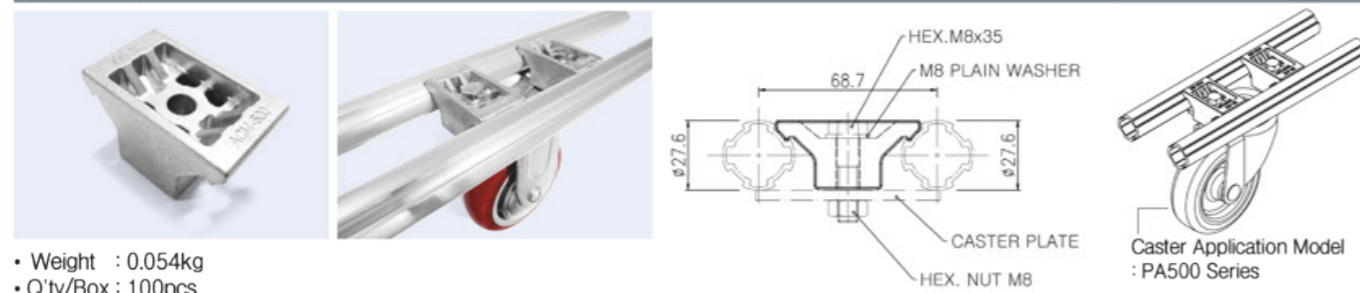

- Weight : 0.054kg
- Q'ty/Box : 100pcs

ACP-H6026A Aluminum Connector Piece

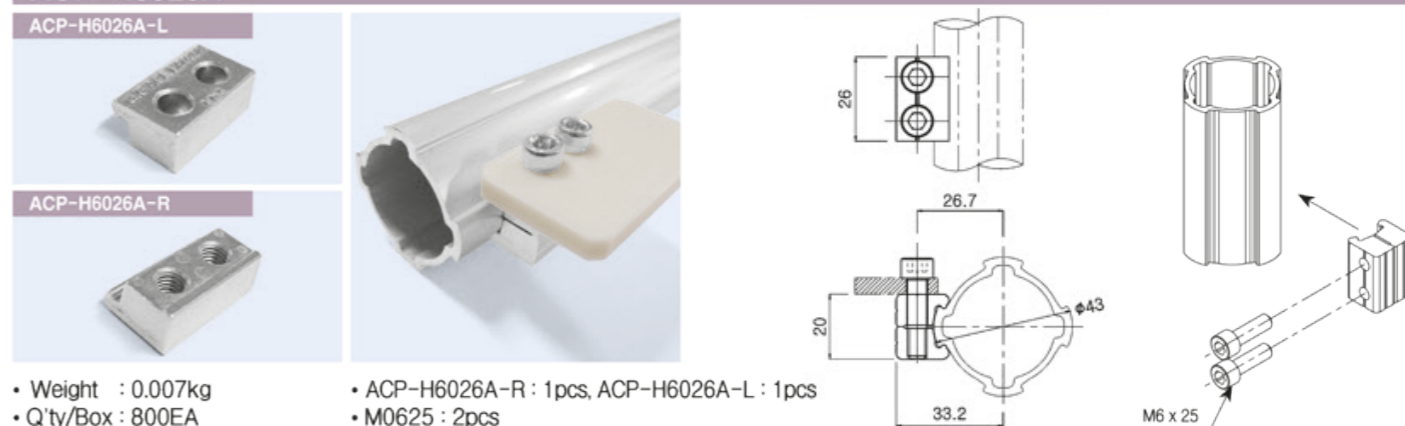

- ACP-H6026A-L
- ACP-H6026A-R
- Weight : 0.007kg
- Q'ty/Box : 800EA
- ACP-H6026A-R : 1pcs, ACP-H6026A-L : 1pcs
- M0625 : 2pcs

ACP-V6026A Aluminum Connector Piece

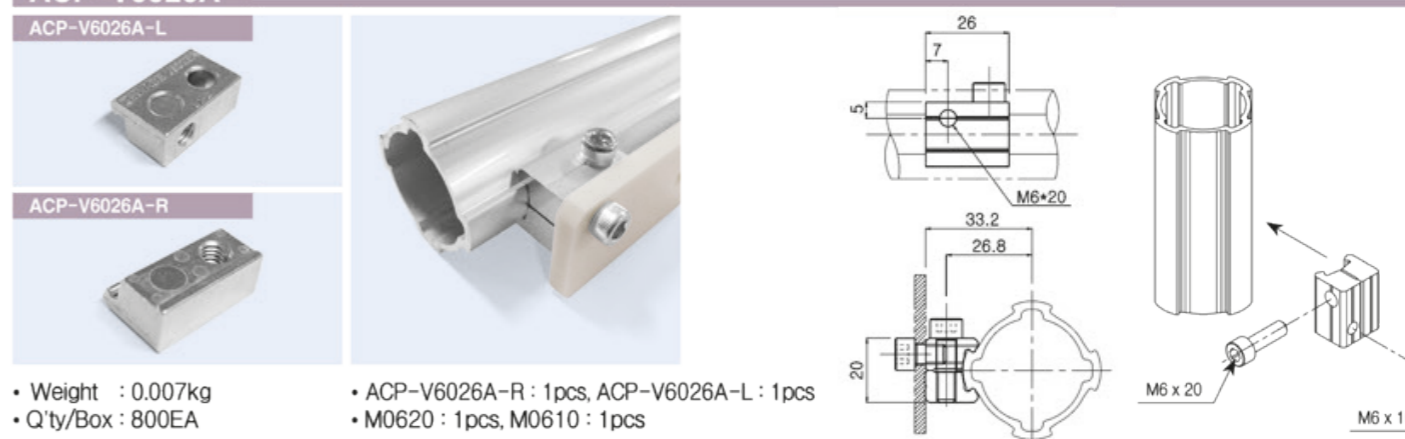

- ACP-V6026A-L
- ACP-V6026A-R
- Weight : 0.007kg
- Q'ty/Box : 800EA
- ACP-V6026A-R : 1pcs, ACP-V6026A-L : 1pcs
- M0620 : 1pcs, M0610 : 1pcs



Unit : mm

Unit : mm

ADR-05-SA Door Rail

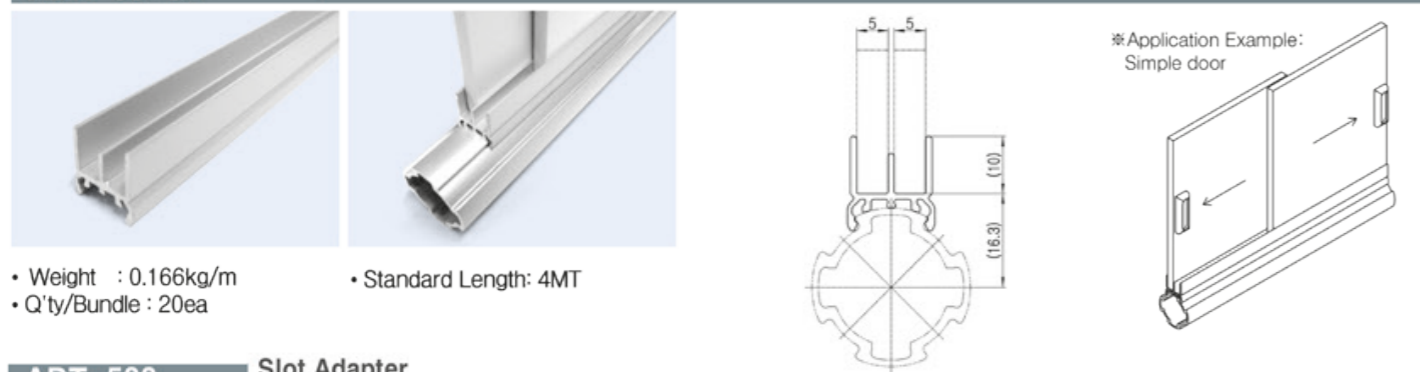

- Weight : 0.166kg/m
- Q'ty/Bundle : 20ea
- Standard Length: 4MT

ADT-500 Slot Adapter

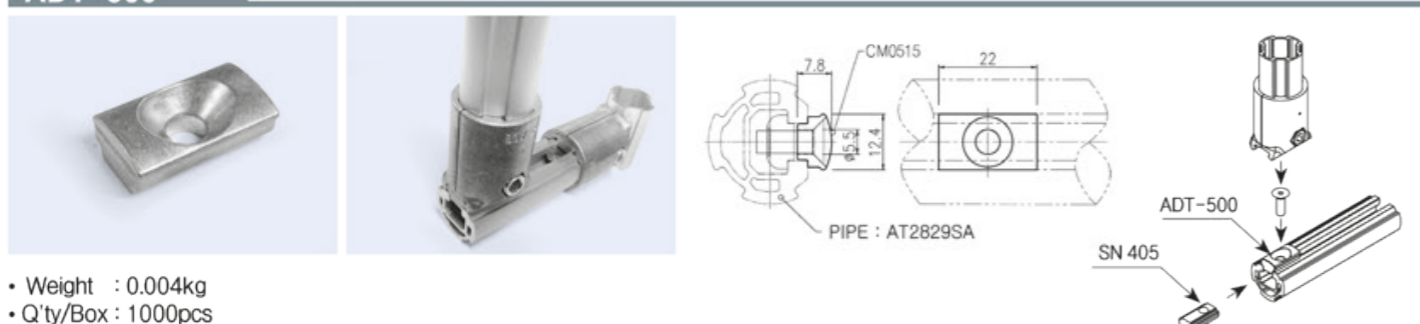

- Weight : 0.004kg
- Q'ty/Box : 1000pcs



ADT-5043A Slot Adapter

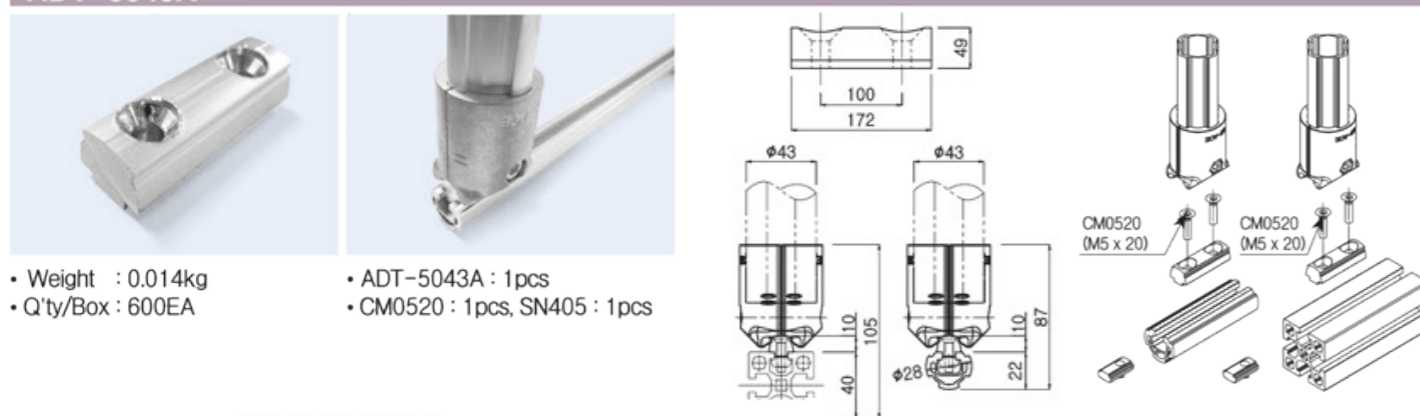

- Weight : 0.014kg
- Q'ty/Box : 600EA
- ADT-5043A : 1pcs
- CM0520 : 1pcs, SN405 : 1pcs

ANP-01-150 AL Name Plate

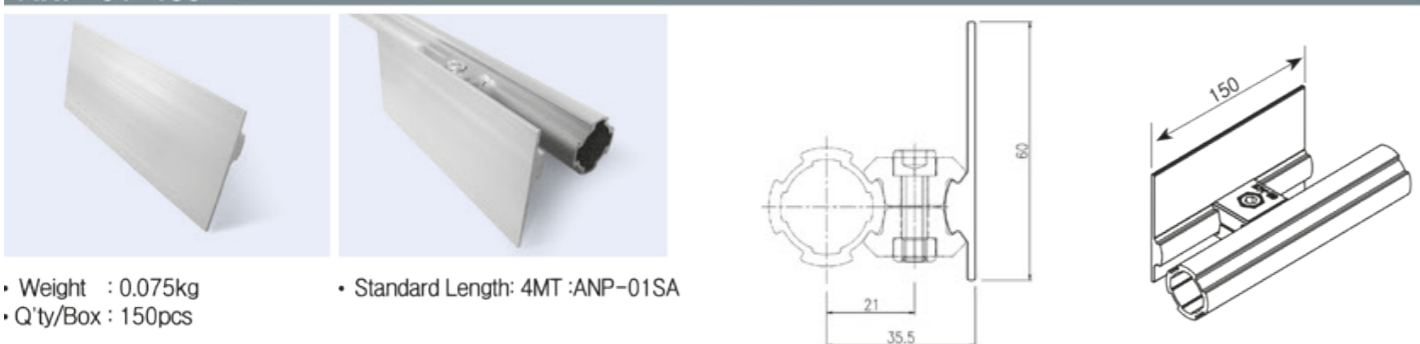

- Weight : 0.075kg
- Q'ty/Box : 150pcs
- Standard Length: 4MT :ANP-01SA

APC-01 Pipe Cover

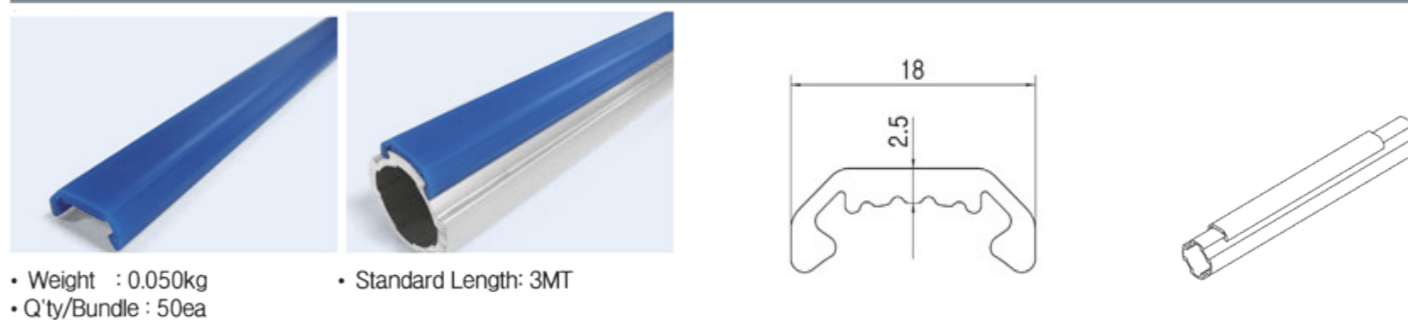

- Weight : 0.050kg
- Q'ty/Bundle : 50ea
- Standard Length: 3MT

APC-03 Pipe Cover

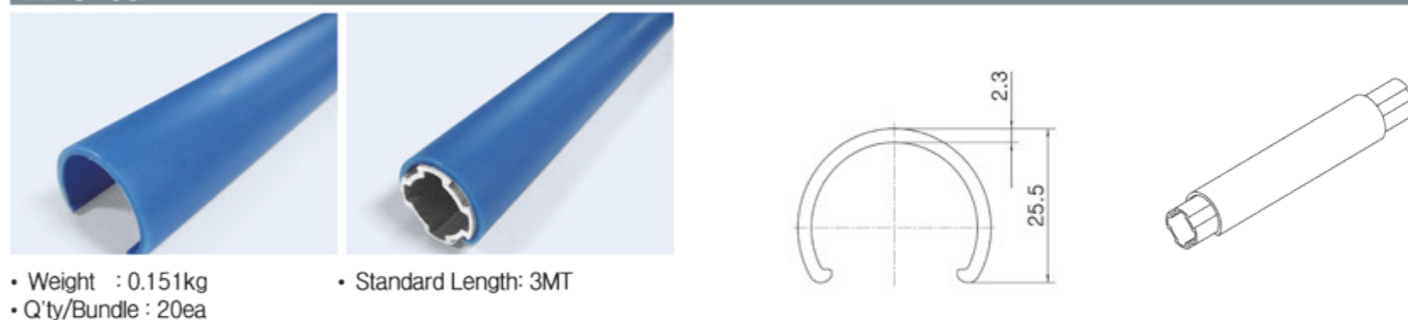

- Weight : 0.151kg
- Q'ty/Bundle : 20ea
- Standard Length: 3MT

APH-633L, APH-633R Round Pipe Connect Joint

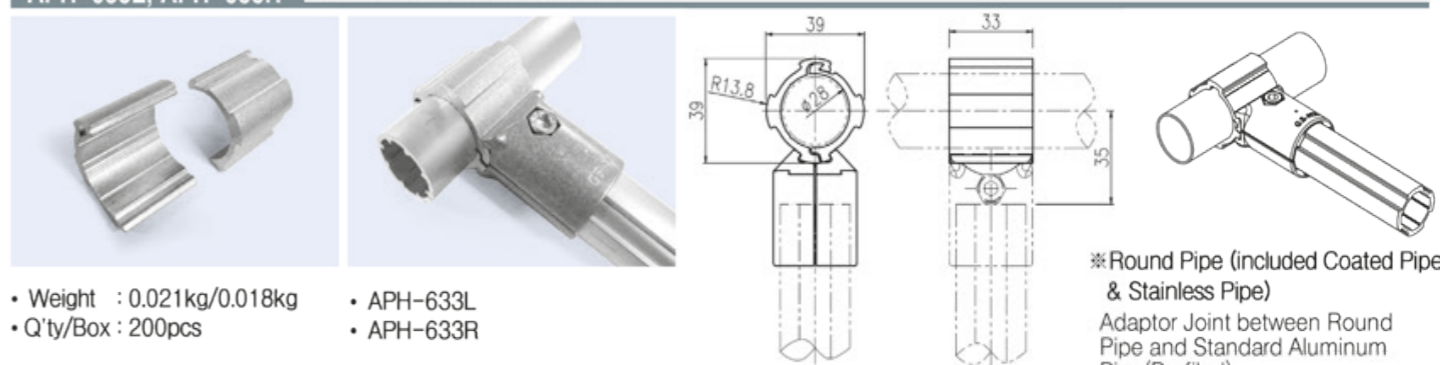

- Weight : 0.021kg/0.018kg
- Q'ty/Box : 200pcs
- APH-633L
- APH-633R

APH-3030A Round Pipe Connected Joint

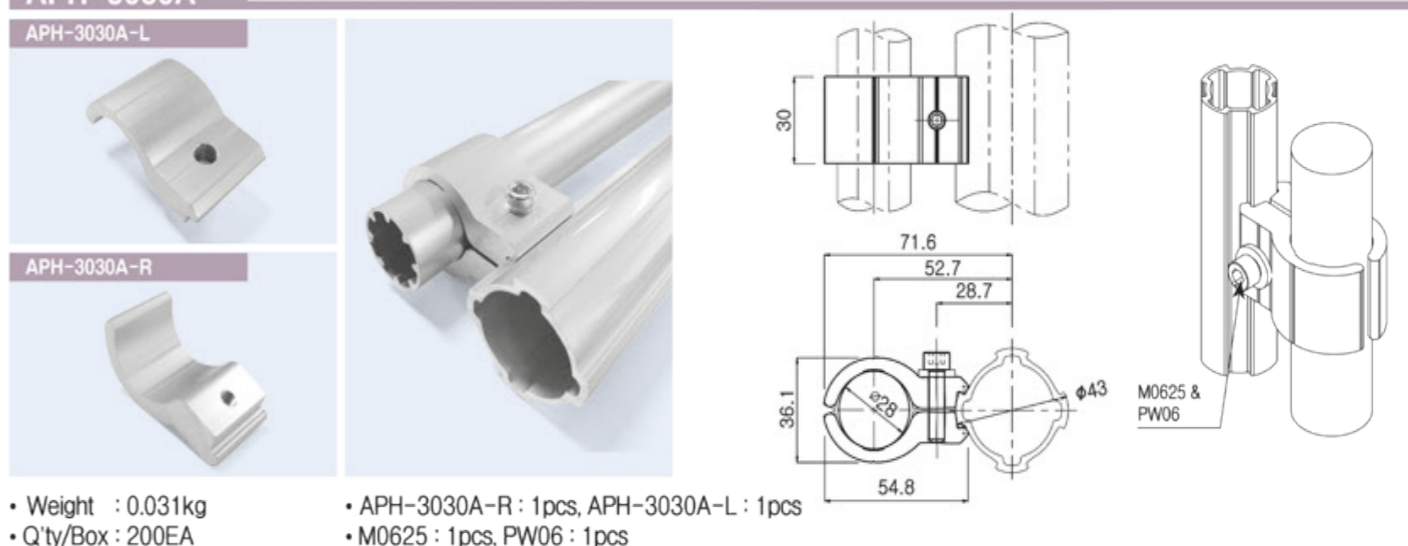

- Weight : 0.031kg
- Q'ty/Box : 200EA
- APH-3030A-R : 1pcs, APH-3030A-L : 1pcs
- M0625 : 1pcs, PW06 : 1pcs

Unit : mm

Unit : mm

ASG-05SA AL Sheet Guide

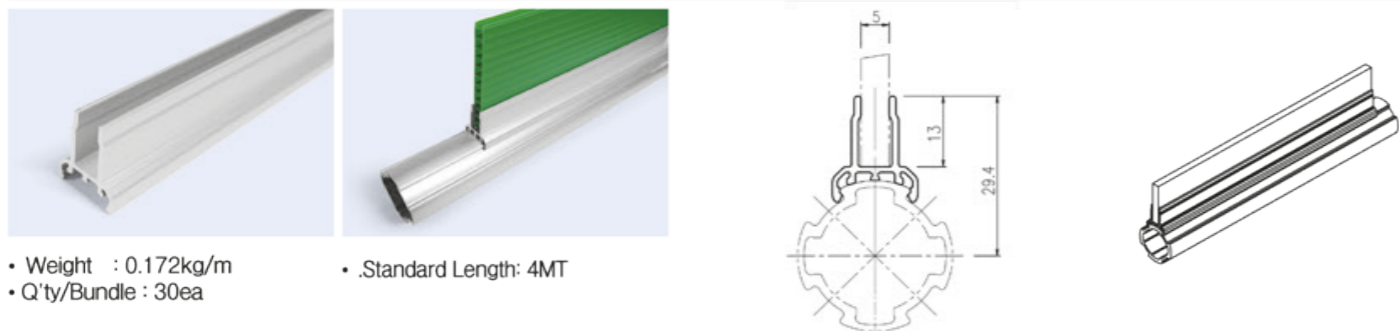

- Weight : 0.172kg/m
- Q'ty/Bundle : 30ea
- Standard Length: 4MT

ASR-52 Slot Roller

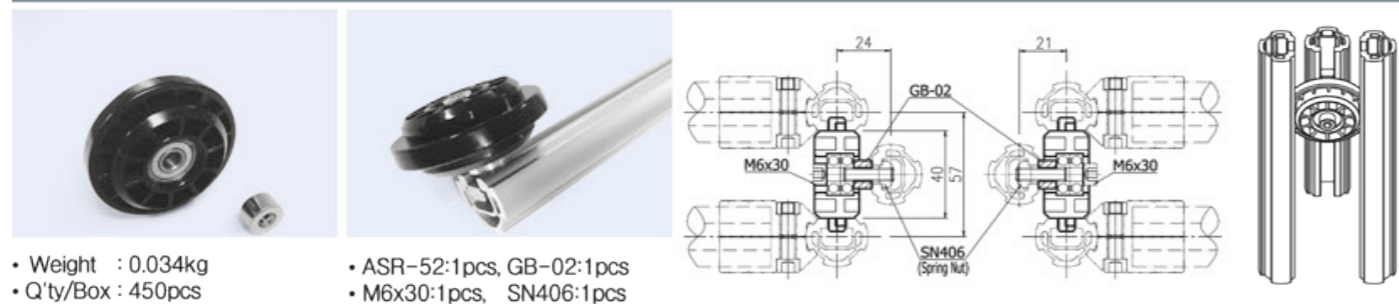

- Weight : 0.034kg
- Q'ty/Box : 450pcs
- ASR-52:1pcs, GB-02:1pcs
- M6x30:1pcs, SN406:1pcs

AWM-2500A SA AL Wall Mount

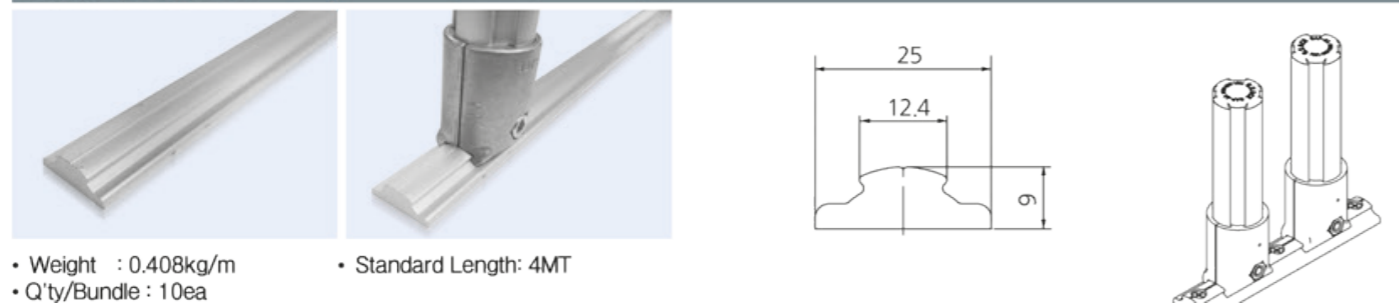

- Weight : 0.408kg/m
- Q'ty/Bundle : 10ea
- Standard Length: 4MT

B-013L, B-013R 45° Joint

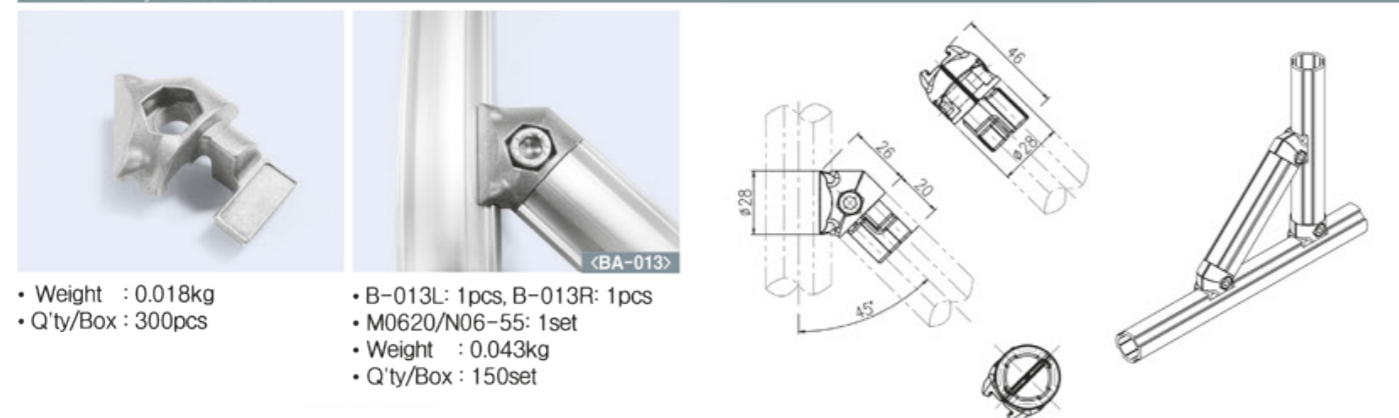

- Weight : 0.018kg
- Q'ty/Box : 300pcs
- B-013L: 1pcs, B-013R: 1pcs
- M0620/N06-55: 1set
- Weight : 0.043kg
- Q'ty/Box : 150set

B-017A-08 Panel Joint

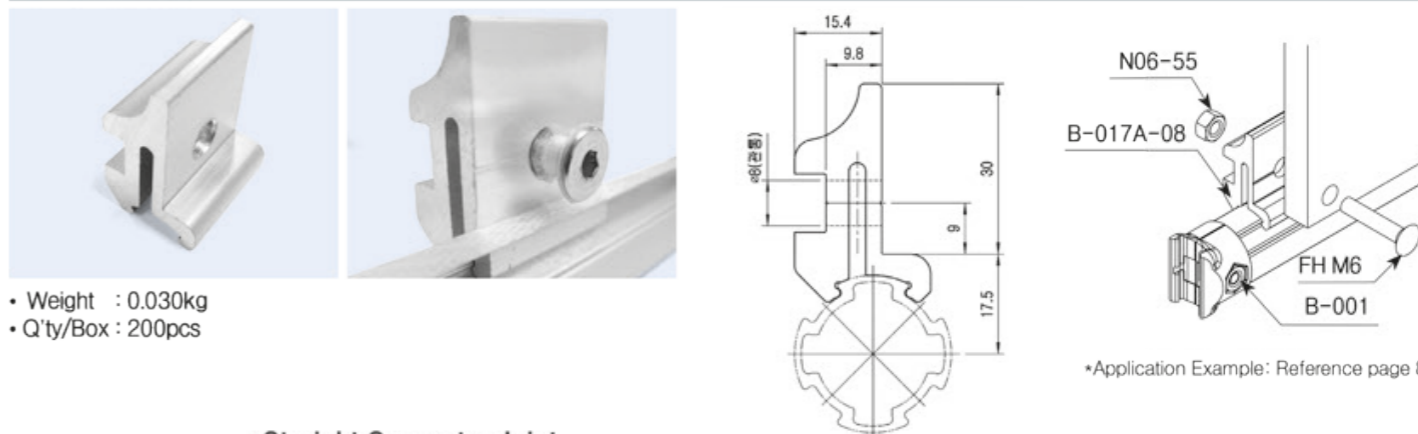

- Weight : 0.030kg
- Q'ty/Box : 200pcs

• Application Example: Reference page 89

B-044 Straight Connector Joint

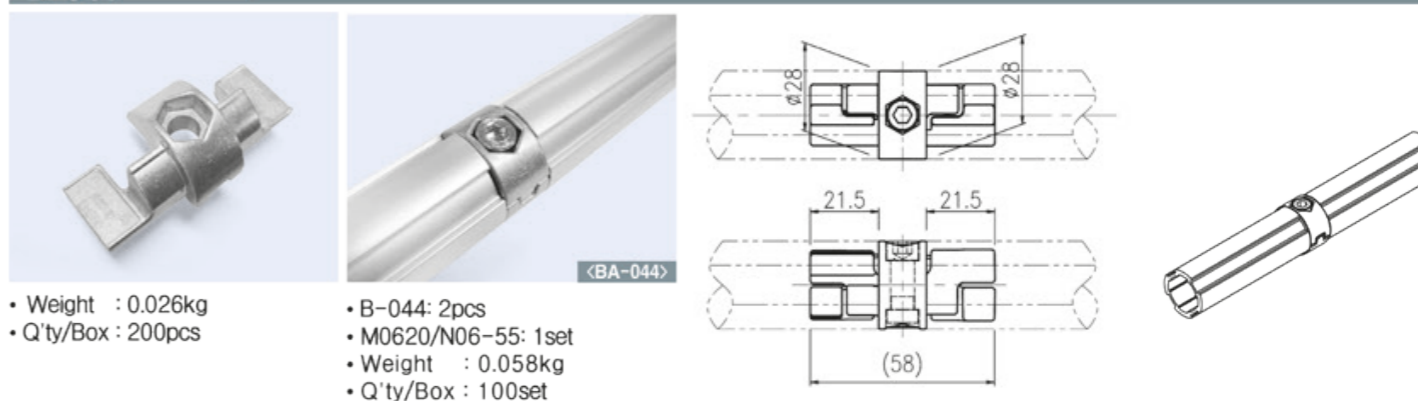

- Weight : 0.026kg
- Q'ty/Box : 200pcs

- B-044: 2pcs
- M0620/N06-55: 1set
- Weight : 0.058kg
- Q'ty/Box : 100set

B-045 Corner Joint

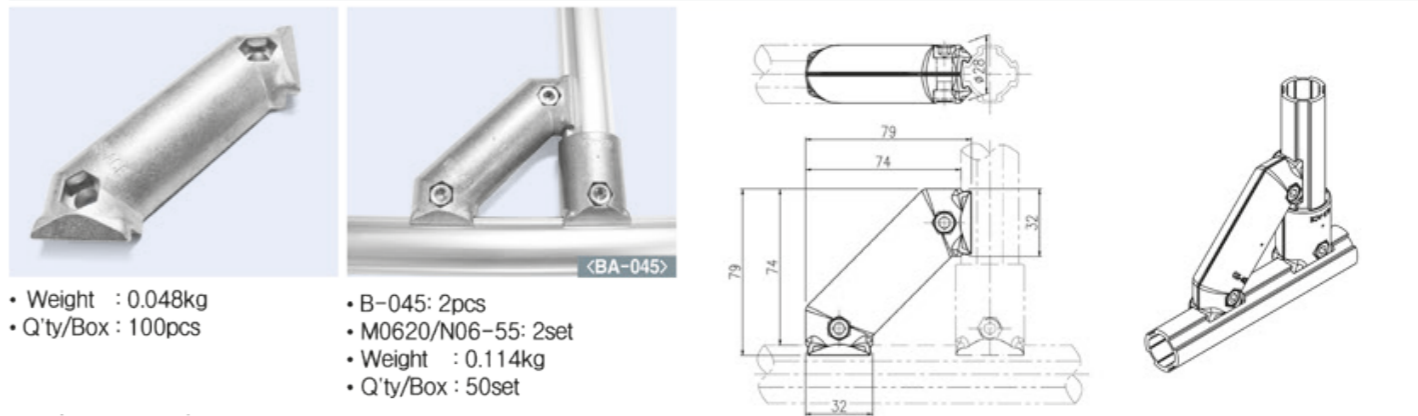

- Weight : 0.048kg
- Q'ty/Box : 100pcs

- B-045: 2pcs
- M0620/N06-55: 2set
- Weight : 0.114kg
- Q'ty/Box : 50set

IN404/405/406/408 Insert Nut

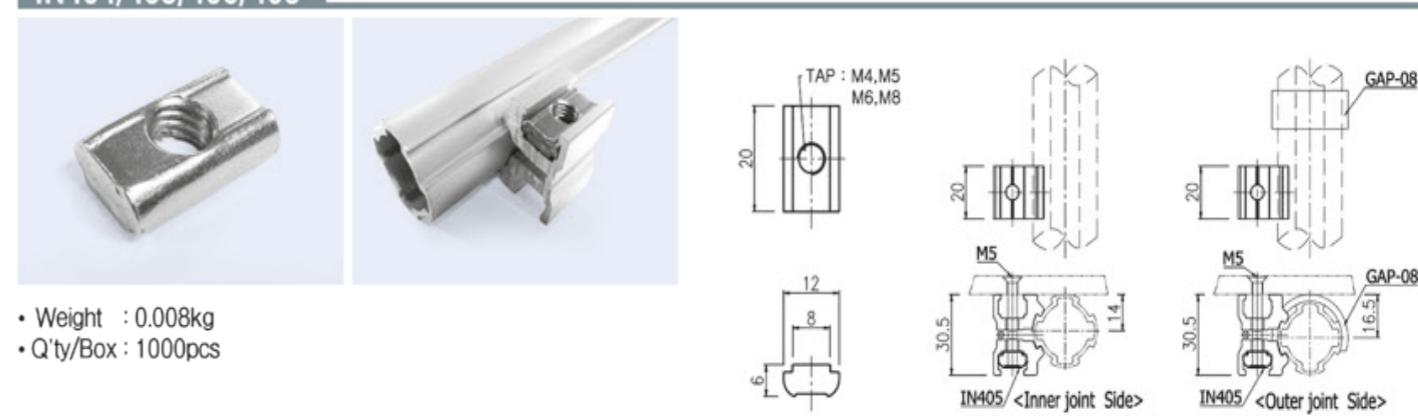

- Weight : 0.008kg
- Q'ty/Box : 1000pcs

Unit : mm

LP2800 ELF Plate

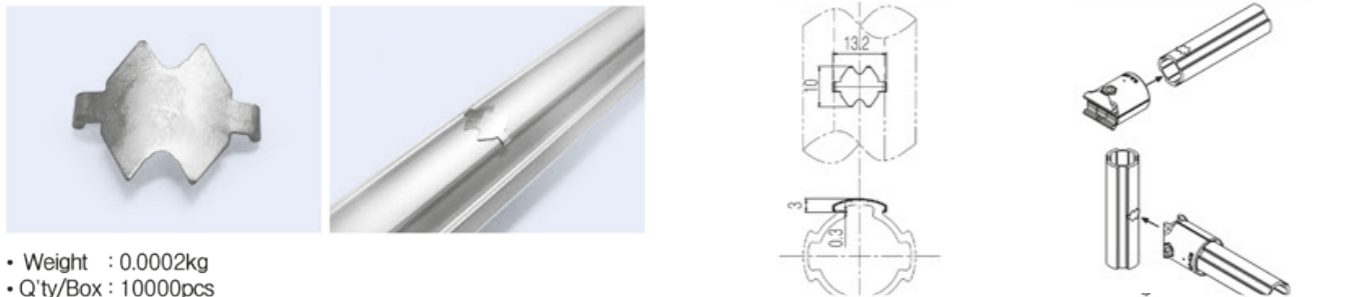

• Weight : 0.0002kg
• Q'ty/Box : 10000pcs

SN403/404/405/406/408 Spring Nut

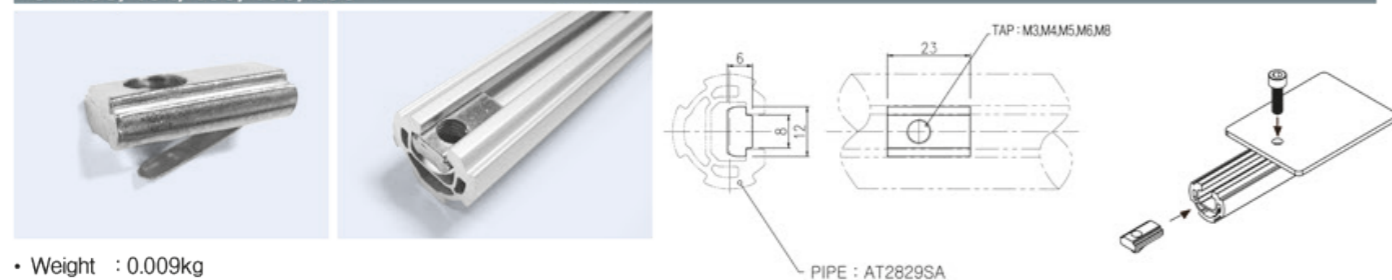

• Weight : 0.009kg
• Q'ty/Box : 1000pcs

BA-206 Crossover Joint (Angle Adjustable)



• B-206A: 1pcs, B-206B: 1pcs, B-206C: 1pcs, B-206D: 1pcs
• M0620/N06-55: 2set, M0625: 1pcs
• Weight : 0.117kg
• Q'ty/Box : 60set

• Weight : 0.020kg
• Q'ty/Box : 300pcs

• Weight : 0.020kg
• Q'ty/Box : 300pcs

• Weight : 0.035kg
• Q'ty/Box : 200pcs

• Weight : 0.020kg
• Q'ty/Box : 300pcs

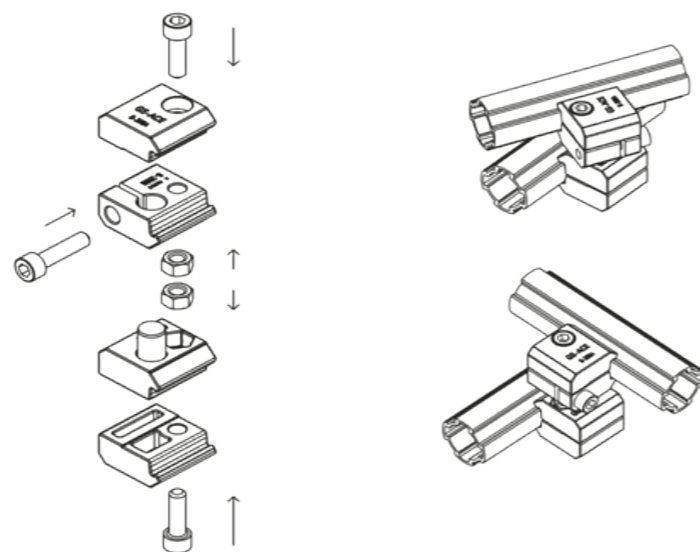
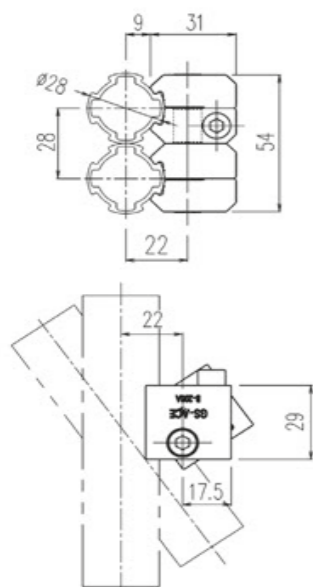

METAL HOLDER

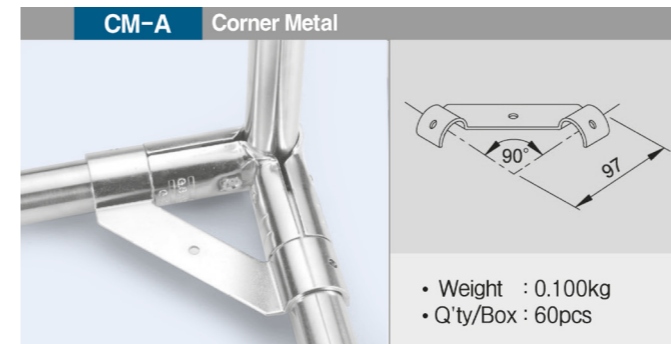

• Weight : 0.100kg
• Q'ty/Box : 60pcs

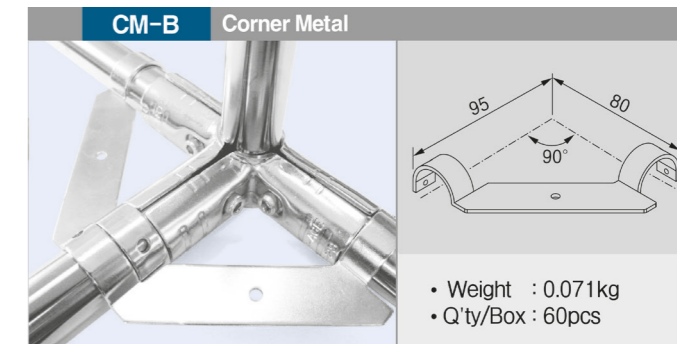

• Weight : 0.071kg
• Q'ty/Box : 60pcs

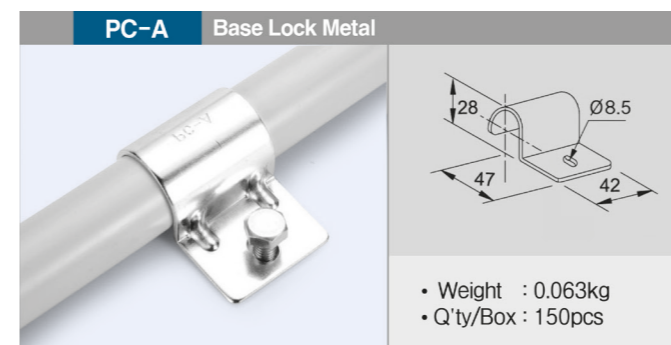

• Weight : 0.063kg
• Q'ty/Box : 150pcs

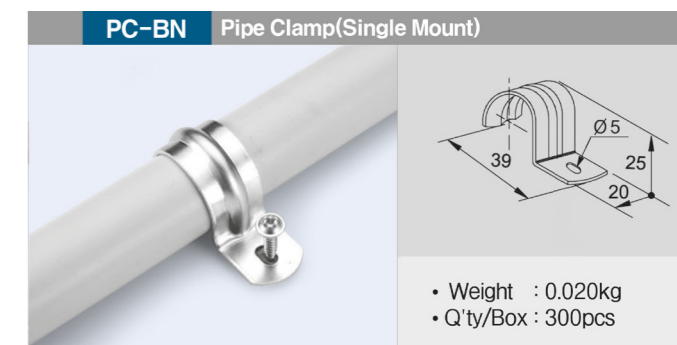

• Weight : 0.020kg
• Q'ty/Box : 300pcs

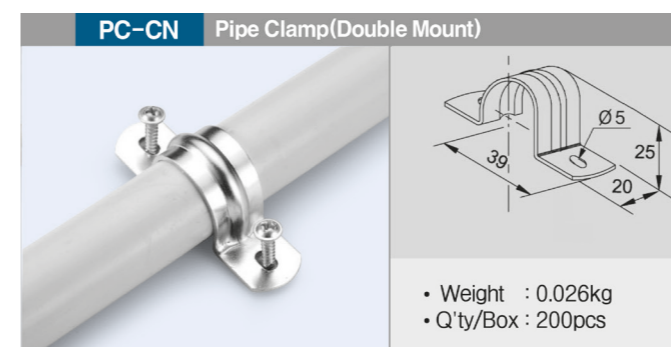

• Weight : 0.026kg
• Q'ty/Box : 200pcs

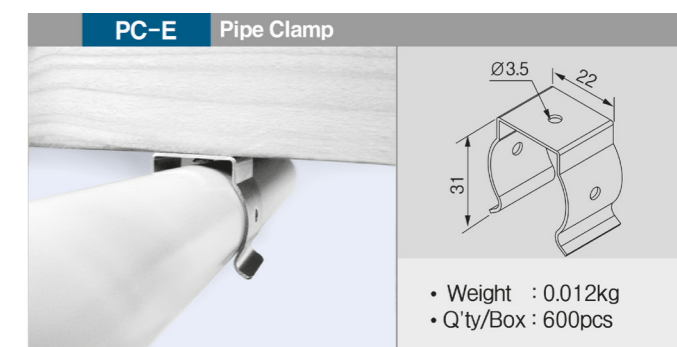

• Weight : 0.012kg
• Q'ty/Box : 600pcs



PLASTIC HOLDER

Unit : mm

GAP-7 Plastic Joint

- Weight : 0.011kg
- Q'ty/Box : 450pcs

GAP-8FN Horizontal Holder

- Weight : 0.005kg
- Q'ty/Box : 1200pcs

GAP-6 Label Holder

- Weight : 0.005kg
- Q'ty/Box : 1200pcs

GAP-6B Label Holder

- Weight : 0.005kg
- Q'ty/Box : 1200pcs

GAP-15 Sheet Holder

- Weight : 0.003kg
- Q'ty/Box : 1500pcs

GAP-17 Plastic Joint

- Weight : 0.014kg
- Q'ty/Box : 400pcs

GAP-20 Name Plate Holder

- Weight : 0.006kg
- Q'ty/Box : 1200pcs

GAP-55 Name Plate Holder (Assembled NP-B)

*firmly secured by M4 screw and nut

Sold separately Bolt & Nut

- Weight : 0.009kg
- Q'ty/Box : 750pcs

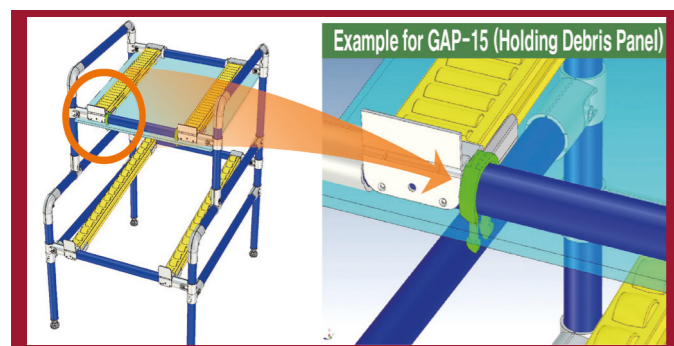

GAP-46 Plastic Joint

- Weight : 0.013kg
- Q'ty/Box : 450pcs

GAP-65 Corner Support Cap

Patent Pending

- Weight : 0.015kg
- Q'ty/Box : 400pcs

LA Label Case

- Weight : 0.044kg
- Q'ty/Box : 300pcs



LA-A3 Label Case

- Weight : 0.170kg
- Q'ty/Box : 200pcs

LA-C Label Case

- Weight : 0.050kg
- Q'ty/Box : 200pcs

STRUT

GAP-11 Taper Edge

- Weight : 0.002kg
- Q'ty/Box : 2500pcs

GAP-8 Horizontal Holder

- Weight : 0.005kg
- Q'ty/Box : 1200pcs



Unit : mm

LA-D Label Case

- Weight : 0.012kg
- Q'ty/Box : 300pcs

LA-E Label Case

- Weight : 0.027kg
- Q'ty/Box : 300pcs

LC Label Case

- Weight : 0.027kg
- Q'ty/Box : 300pcs

NP-A Name Plate

- Weight : 0.079kg
- Q'ty/Box : 180pcs

NP-B Name Plate

- Weight : 0.047kg
- Q'ty/Box : 360pcs

NP-C Name Plate

- Weight : 0.035kg
- Q'ty/Box : 190pcs

NP-D Name Plate

- Weight : 0.032kg
- Q'ty/Box : 190pcs

NP-E Name Plate

- Weight : 0.023kg
- Q'ty/Box : 450pcs

NP-F Name Plate (Requires GAP-58, sold separately)

- Weight : 0.017kg
- Q'ty/Box : 1,000pcs

NP-R Name Plate

- Weight : 0.011kg
- Q'ty/Box : 1,000pcs

Unit : mm

GAP-3 Outer Cap

- Weight : 0.009kg
- Q'ty/Box : 900pcs

GAP-4P Inner Cap

- Weight : 0.003kg
- Q'ty/Box : 1500pcs

GAP-4R Rubber Cap

- Weight : 0.009kg
- Q'ty/Box : 900pcs



GAP-4A Inner Cap

- Weight : 0.003kg
- Q'ty/Box : 1500pcs

Part No.	Colors	Marking	Material
GAP-4A-G	Gray		Plastic
GAP-4A-B	Black	GAP-4A	
GAP-4A-i	Ivory		

GAP-4AT T Slot Inner Cap

- Weight : 0.002kg
- Q'ty/Box : 1500pcs

Part No.	Colors	Marking	Material
GAP-4AT-G	Gray		Plastic
GAP-4AT-B	Black	GAP-4AT	
GAP-4AT-i	Ivory		

GAP-43A Inner Cap

- Weight : 0.005kg
- Q'ty/Box : 900EA

Part No.	Colors	Marking	Material
GAP-43A-G	Gray		Plastic
GAP-43A-B	Black	GAP-43A	
GAP-43A-i	Ivory		

Unit : mm

GAP-9C Grip Bushing(Coating Pipe:Ø28×T1.0)

- Weight : 0.016kg
- Q'ty/Box : 450pcs

GAP-9S Grip Bushing(STS Pipe:Ø28×T0.7)

- Weight : 0.016kg
- Q'ty/Box : 450pcs

RF-01 Rubber Foot

RF-01 : Normal (D/Gray)
RF-01E : ESD (Black)

- Weight : 0.035kg
- Q'ty/Box : 250pcs

RF-02 Rubber Foot

- Weight : 0.011kg
- Q'ty/Box : 450pcs

GAP-52A Roller Conveyor Cap (With Bearing)

- Weight : 0.013kg
- Q'ty/Box : 1500pcs

GAP-50 Roller Conveyor Cap (Without Bearing)

- Weight : 0.008kg
- Q'ty/Box : 1200pcs

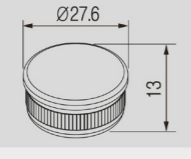
GAM-07S	METAL CAP	Part No	Pipe	Diameter	Remark
		GAM-07S	STS Pipe	Ø28 X t0.7	WZ
<ul style="list-style-type: none"> • Weight : 0.037kg • Q'ty/Box : 500pcs 					

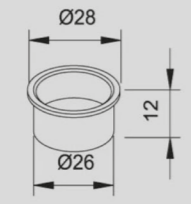
GAS-07S	STEEL CAP	Part No	Pipe	Diameter	Remark
		GAS-07A	Coated Pipe	Ø28x t 0.7	WZ
<ul style="list-style-type: none"> • Weight : 0.009kg • Q'ty/BOX : 600pcs 		GAS-10A	Coated Pipe	Ø28x t 1.0	WZ
		GAS-07S	STS/Eco Pipe	Ø28x t 0.7	WZ
		GAS-12S	STS/Eco Pipe	Ø28x t 1.2	WZ

Unit : mm

INNER CAP

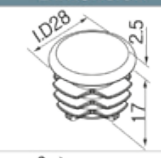
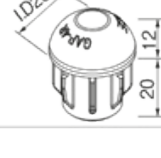
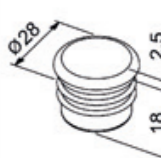
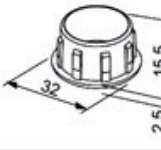
Classification	Part No	Colors	Marking	Material	Dimension
Ø28	GAP-4P-i	Ivory	GAP-4P	Plastic	
	GAP-4P-B	Black			
	GAP-4P-G	Gray			
	GAP-4R-B	Black	GAP-4R		
	GAP-4C-i	Ivory	GAP-4C		
	GAP-4C-B	Black			
GAP-4C-G	Gray				
Ø32	GAP-4S-i	Ivory	GAP-4S		
	GAP-4S-B	Black			
	GAP-4S-G	Gray			
	GAP-4310-i	Ivory	GAP-4310		
	GAP-4310-B	Black			
	GAP-4310-G	Gray			

SAFETY CAP

ASC-V30 Vertical Safety Cap

- Weight : 0.001kg
- Q'ty/Box : 6000kg

ASC-H42R Horizontal Safety Cap

- Weight : 0.001kg
- Q'ty/Box : 4000pcs

ASC-H42L Horizontal Safety Cap

- Weight : 0.002kg
- Q'ty/Box : 4000pcs

ASC-V45 Vertical Safety Cap

- Weight : 0.002kg
- Q'ty/Box : 4000pcs

Unit : mm

PRC-25A Recycle Roller Cap

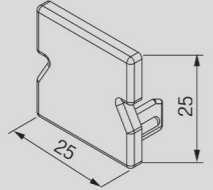
- Weight : 0.002kg
- Q'ty/Box : 1500pcs

PRC-35 Roller Track Cap

- Weight : 0.004kg
- Q'ty/Box : 1000pcs

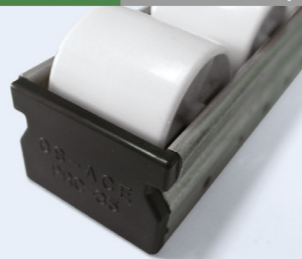
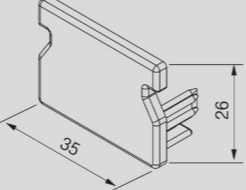
PRC-40 Roller Track Cap

- Weight : 0.005kg
- Q'ty/Box : 1000pcs

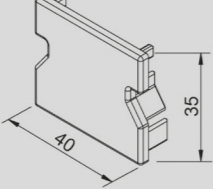
PRC-40A Recycle Roller Cap

- Weight : 0.005kg
- Q'ty/Box : 1000pcs

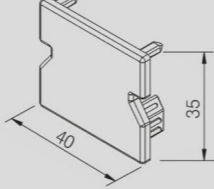
PRC-60 Roller Track Cap

- Weight : 0.006kg
- Q'ty/Box : 600pcs

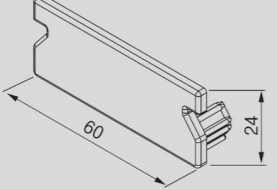

PRC-60B Recycle Roller Cap

- Weight : 0.007kg
- Q'ty/Box : 600pcs

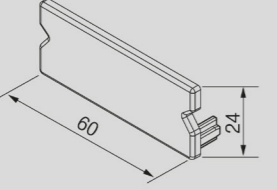
PRC-60A Recycle Roller Cap

- Weight : 0.009kg
- Q'ty/Box : 600pcs

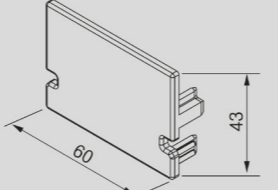
PRC-85A Recycle Roller Cap

- Weight : 0.010kg
- Q'ty/Box : 400pcs

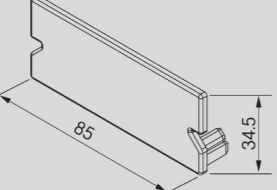

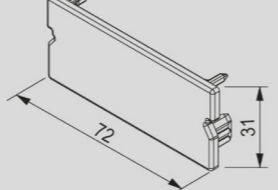

PRC-70A Recycle Roller Cap

- Weight : 0.008kg
- Q'ty/Box : 600pcs

THREAD INSERTS

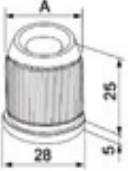
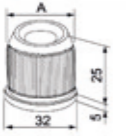
Unit : mm

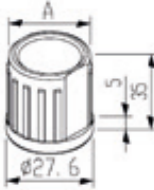
	Part No	Classification	Application	Colors	Threaded Spex	Material	A	Dimension	
	BC2807D	Coated Pipe	Ø28 x t0.7	White	M10-P1.5	Steel	Ø24.1		
	BC2810A				1/2" - P1.5		Ø23.5		
	BC2810B		Ø28 x t1.0	White	M12 - P1.75	Steel	Ø23.5		
	BC2810D				M10 - P1.5				
	BC2820A		Ø28 x t2.0	White	1/2" - 12N	Steel	Ø21.9		
	BC2820B				M12 - P1.75				
	BC2820D				M10 - P1.5				
	BS07A				STS Pipe				Ø28 x t0.7
	BS07B		M12 - P1.75	Ø26.3					
	BS07D		M10 - P1.5						
	BS12A		Ø28 x t1.2	White		1/2" - 12N	Steel		Ø25.5
	BS12B					M12 - P1.75			Ø25.3
BS12D	M10 - P1.5								
	BC3210A	Coated Pipe	Ø32 x t1.0	White	1/2" - 12N	Steel	Ø27.5		
	BC3210B				M12 - P1.75				
	AS2807A	STS Pipe	Ø28 x t0.7	Gray	M12 - P1.75	Aluminium	Ø26.5		
	AS2801B				1/2" - 12N				
	AC2809A	Coated Pipe	Ø28 x t1.0		M12 - P1.75		Ø23.8		
	AC2809B				1/2" - 12N				
	OB28AN	All Pipe	Ø28	White	1/2" - 12N	Steel	Ø27.7		
	OB28BN				M12 - P1.75				

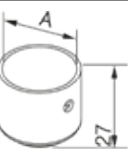
Unit : mm

BA2800A/B AL Thread Insert

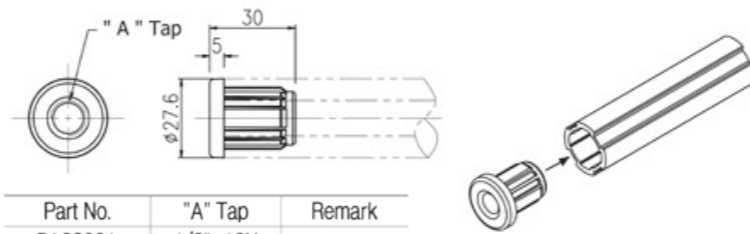
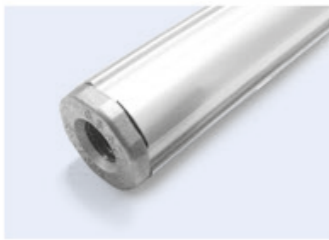

- Weight : 0.017kg
- Q'ty/Box : 300pcs

Part No.	"A" Tap	Remark
BA2800A	1/2"-12N	
BA2800B	M12-p1.75	

BP2800A/B AL Plastic Thread Insert

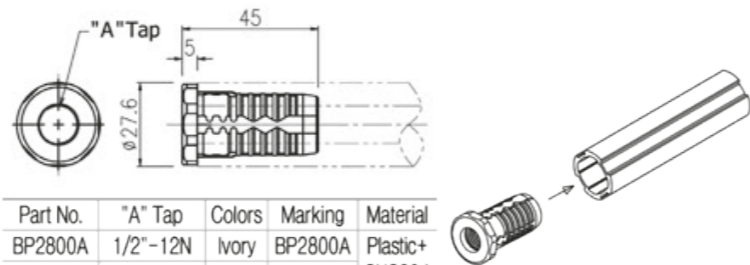
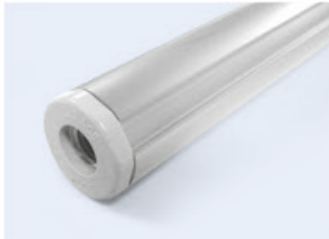

- Weight : 0.011kg
- Q'ty/Box : 800pcs

Part No.	"A" Tap	Colors	Marking	Material
BP2800A	1/2"-12N	Ivory	BP2800A	Plastic+
BP2800B	M12-p1.75	Gray	BP2800B	SUS304

BP2800H AL Plastic Thread Insert

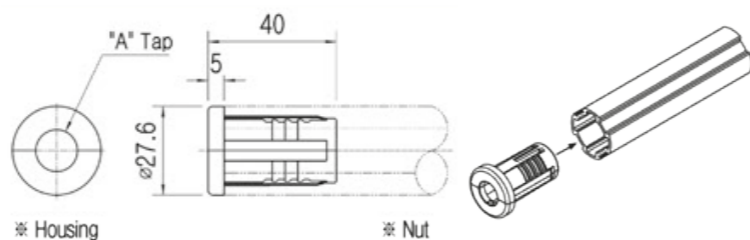
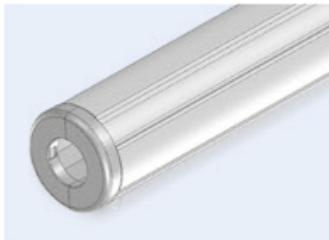
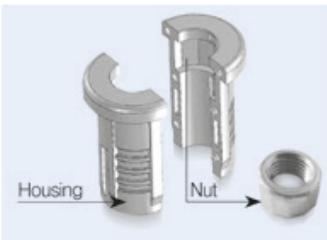

- Weight : 0.011kg
- Q'ty/Box : 800pcs
- Housing : 2pcs
- Nut : 1pcs

Part No.	Colors	Remark	"A" Tap	Part No.	Remark
BP2800	Gray		M12	N12-S12(SUS 304)	Special
			1/2"-12N	N1/2"-S12(SUS 304)	

BP4300H AL Plastic Thread Insert

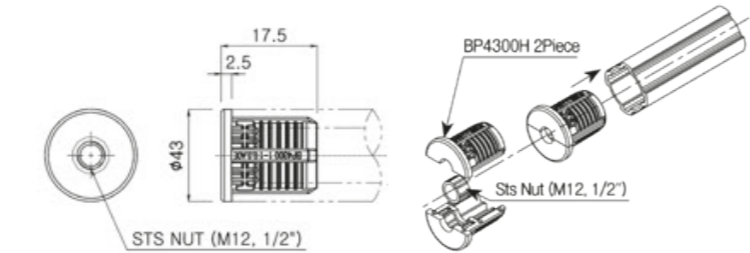
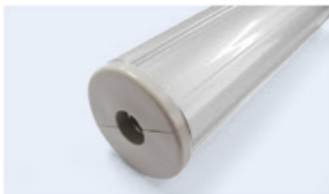

- Weight : 0.014kg
- Q'ty/Box : 800EA
- BP4300H : 2pcs, Sts Nut : 1pcs

BP4300H 2Piece
Sts Nut (M12, 1/2")
STS NUT (M12, 1/2")

Unit : mm

SMALL TYPE

AD30PA LEVELING FOOT

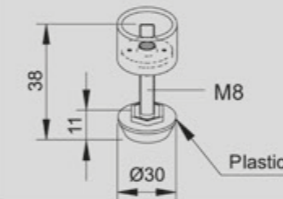

- Weight : 0.035kg
- Q'ty/Box : 150pcs

AD32WA LEVELING FOOT

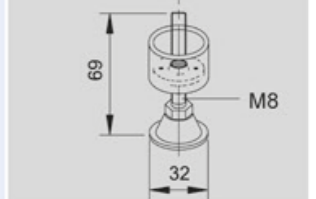

- Weight : 0.053kg
- Q'ty/Box : 125pcs

NORMAL TYPE

Part No	Base Diameter	Threaded Spec	Threaded Length	ESD	Type
AD32WB	Ø32	1/2"-12N	50	○	
AD32WC			100	○	
AD50WA/B	Ø50	1/2"-12N	50	○	
AD50WB			100	○	
AD50WA-B-AC	Ø50	1/2"-12N	50	○	
AD50WB-AC			100	○	

STS TYPE

Part No	Base Diameter	Threaded Spec	Threaded Length	ESD	Type
AD35SA	Ø35	1/2"-12N	50	○	
AD35SB			100	○	
AD40SPA	Ø40	1/2"-12N (Rubber Type)	50	○	
AD40SPB			100	○	

RUBBER PAD-TYPE

Part No	Base Diameter	Threaded Spec	Threaded Length	ESD	Type
AD50RAN	Ø50	1/2"-12N	50	×	
AD50RAN-E			50	○	
AD50RBN			100	×	
AD50RBN-E			100	○	
AD32RA	Ø32	1/2"-12N	50	×	
AD32RA-E			50	○	
AD32RB			100	×	
AD32RB-E			100	○	

Unit : mm

AD-SM Stanchion Mount Single

- Weight : 0.198kg
- Q'ty/Box : 20pcs



AP-50 Anchor Plate

- Weight : 0.052kg
- Q'ty/Box : 220pcs

HC28A Hole Cup-A

- Weight : 0.300kg
- Q'ty/Box : 20pcs



AD-SM43A Stanchion Mount Single

- Weight : 0.680kg
- AD-SM43A : 1pcs,
- HM0615 : 1pcs

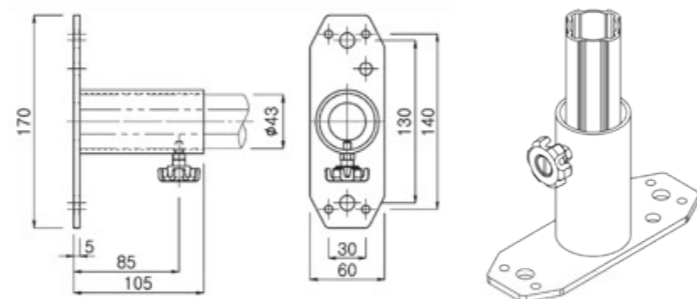

Fastener Type	Part No	Item	Spec	Colors	Usage
	TN06W	T-Nut	M6	White	Metal Joint
	TN06B		M6	Black	
	SW10W	Spring Washer	M10	White	M10Bolt
	SW13W		M12		M12Bolt
	PW05W	Flat Washer	M5	White	M5Bolt
	PW10W		M10		M10Bolt

Fastener Type	Part No	Item	Spec	Colors	Usage		
	M0610W	M6x10	P 1.0	White	Metal Joint		
	M0610B		P 1.0	Black			
	M0625W	M6x25	P 1.0	White	Metal Joint		
	M0625B		P 1.0	Black			
	M0630W	M6x30	P 1.0	White			
	M0630B		P 1.0	Black			
	M0830W	M8x30	P1.25	White	AL Joint		
	M0840W					M8x40	P1.25
	M1020W	M10Bolt	L20	White	Caster		
	M1225W					M12Bolt	L25
	GM835W					M8Bolt	L35xP1.25
GM840W	M8Bolt	L40xP1.25					
GM845W		L45xP1.25					
GM850W		L50xP1.25					
GM860W		L60xP1.25					
GM870W		L70xP1.25					
		HM0620	Knob Bolt	P1.0	Black	Metal Joint	

	NN06W	Nylon Nut	M6	White	M6Bolt
	NN08W		M8		M8Bolt
	NN10W		M10		M10Bolt
	NN12W		M12		M12Bolt

	N06W	Nut	M6	White	M6 Bolt
	N08W		M8		M8 Bolt
	Ni05W-12	inch Nut	1/2"-12N		inchBolt

Other screws : contact AT Sourcing

Unit : mm

RS - 2B Safety Reflector

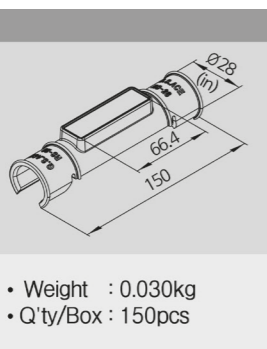
- Weight : 0.030kg
- Q'ty/Box : 150pcs

CD - 28C/D Cable Duct

- CD-28C Weight : 0.026kg/m
- CD-28D Weight : 0.022kg/m

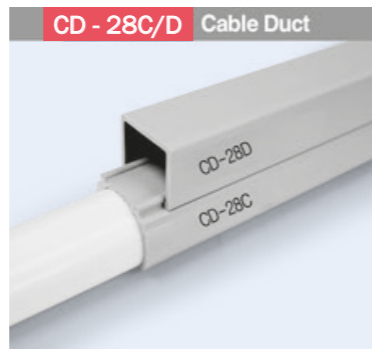
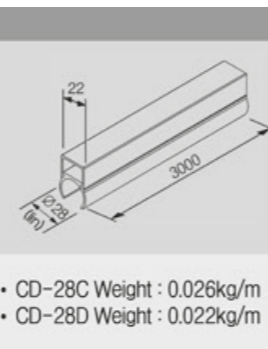
MJC - G1

Matériau : PP

Unit : EA

MJC - G1 ASS'Y

Weight : 12,5 g

Size (mm) : 465 x 260 x 260 (H)

Q'ty / Box : 150 EA

Gross weight : 2 kg

MJC - G1 ASS'Y
Requires MJC-G1 2 EA



MJC - G2

Matériau : PP

Unit : EA

MJC - G4 ASS'Y

Weight : 12,4 g

Size (mm) : 465 x 260 x 260 (H)

Q'ty / Box : 100 EA

Gross weight : 1,6 kg

MJC - G2 ASS'Y
Requires MJC-G2 4 EA

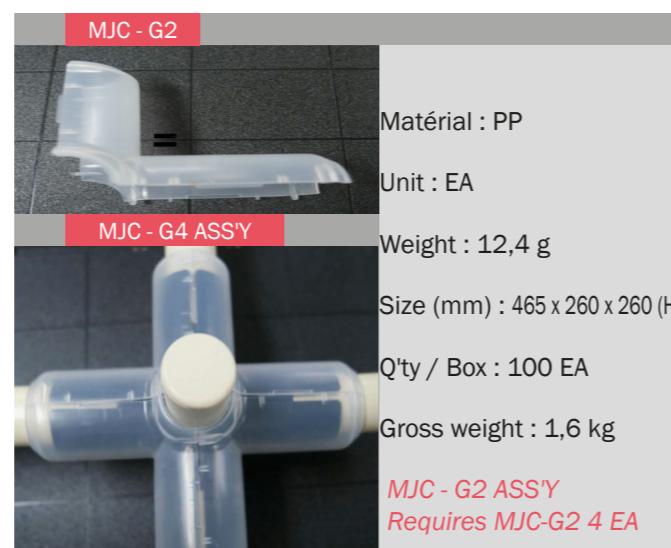

MJC - G3

Matériau : PP

Unit : EA

MJC - G3 ASS'Y

Weight : 20,1 g

Size (mm) : 465 x 260 x 260 (H)

Q'ty / Box : 100 EA

Gross weight : 2,5kg

MJC - G3 ASS'Y
Requires MJC-G2 + MJC-G1



MJC - G4

Matériau : PP

Unit : EA

MJC - G4 ASS'Y

Weight : 19 g

Size (mm) : 465 x 260 x 260 (H)

Q'ty / Box : 100 EA

Gross weight : 2,4kg

MJC - G4 ASS'Y
Requires MJC-G4 2 EA

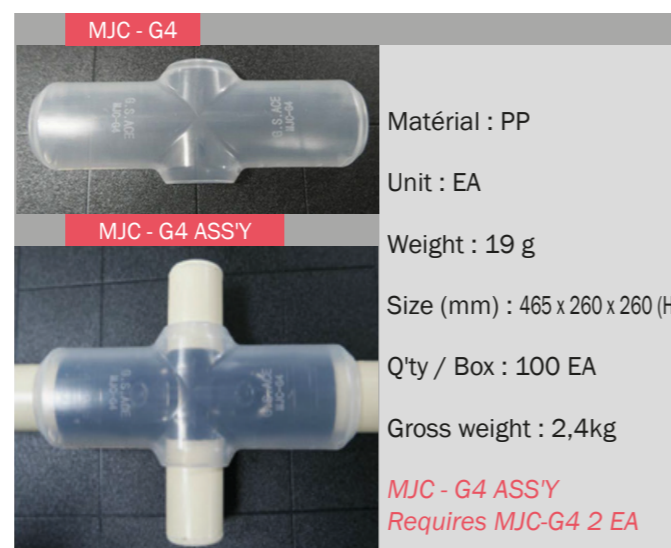

CONVOYER

GAP-48 Roller Conveyor Holder (Single)

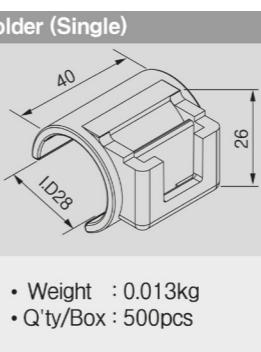
- Weight : 0.013kg
- Q'ty/Box : 500pcs

GAP-49 Roller Conveyor Holder (Double)

- Weight : 0.017kg
- Q'ty/Box : 400pcs

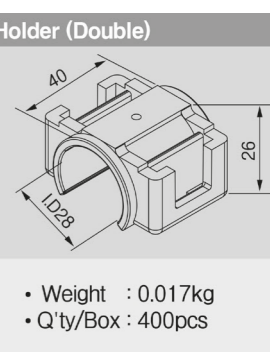
GAP-51 Roller Conveyor Support

- Weight : 0.007kg
- Q'ty/Box : 1200pcs

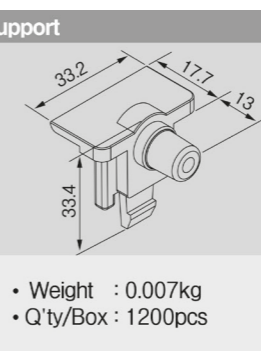
ACCESSORIES

GAP-41 Plastic Joint

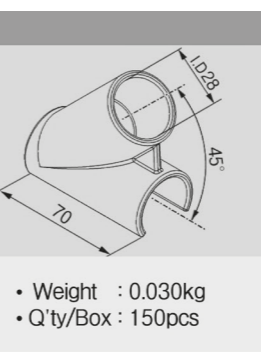

- Weight : 0.030kg
- Q'ty/Box : 150pcs

GAP-42 Plastic Joint

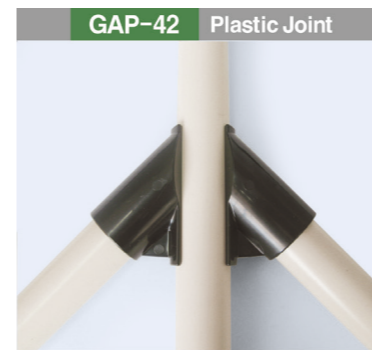
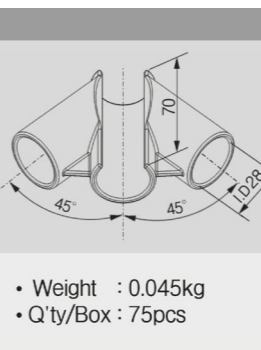
- Weight : 0.045kg
- Q'ty/Box : 75pcs

GAP-43 Plastic Joint

- Weight : 0.028kg
- Q'ty/Box : 150pcs



Unit : mm

Unit : mm

BC45-A Base Corner

- Weight : 1.85kg
- Q'ty/Box : 8pcs

BC45-B Base Center

- Weight : 1.17kg
- Q'ty/Box : 4pcs

BS-01 Box-Stopper (Requires CM-200 : sold separately)

- Weight : 1.78kg
- Q'ty/Box : 8pcs

BS-15 Back Stopper Bracket

- Weight : 0.105kg
- Q'ty/Box : 60pcs



BC45-C Base Center

- Weight : 1.28kg
- Q'ty/Box : 4pcs

BUSH-12 Sleeve Busing(Metal)

- Weight : 0.035kg
- Q'ty/Box : 180pcs

CB-MCP Corner Bumper

- Weight : 0.034kg
- Q'ty/Box : 150pcs

BH-B Band Hook

- Weight : 0.001kg
- Q'ty/Box : 2,000pcs

CP-32 Cover Pulley

- Weight : 0.004kg
- Q'ty/Box : 3000pcs

CS28L Corner Support

- Weight : 0.682kg
- Q'ty/Box : 24pcs

BH-A Band Hook

- Weight : 0.001kg
- Q'ty/Box : 1,000pcs

BL28YA-U Pipe Holder

- Weight : 0.069kg
- Q'ty/Box : 150pcs

CS28R Corner Support

- Weight : 0.750kg
- Q'ty/Box : 24pcs

DL-15 Door Latch

- Weight : 0.305kg
- Q'ty/Box : 40pcs

BRA-32 Bearing Pulley

- Weight : 0.012kg
- Q'ty/Box : 1,000pcs

BKT-40 Curve Roller Mounting

- Weight : 0.055kg
- Q'ty/Box : 200pcs

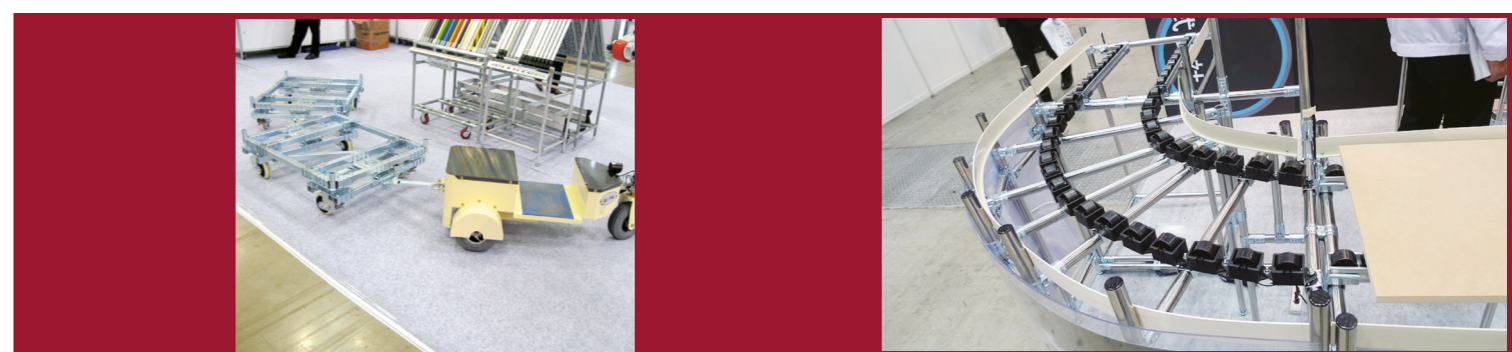

Unit : mm

Unit : mm

ECH-28A End Cap Hanger

- Weight : 0.056kg
- Q'ty/Box : 45pcs

F-A Handle(Flat Type)

- Weight : 0.020kg
- Q'ty/Box : 500pcs

GB-02 Gap Bushing

- Weight : 0.006kg
- Q'ty/Box : 2,000pcs



FH-A Front Haul Ring-A

- Q'ty/Box : 5pcs

GRH-15L Ass'y Bearing Pulley Ass'y Left

- GRH-15L : 1pcs, G-15BS : 1pcs
- BRA-32 : 1pcs, GB-02 : 1pcs
- M0625 : 1pcs, M0610 : 1pcs

GRH-15L Pulley Holder BKT Left

- Weight : 0.055kg
- Q'ty/Box : 270pcs

FH-B Rear Haul Ring-B

- Q'ty/Box : 10pcs

GRH-15R Ass'y Bearing Pulley Ass'y Right

- GRH-15R : 1pcs, G-15BS : 1pcs
- BRA-32 : 1pcs, GB-02 : 1pcs
- M0625 : 1pcs, M0610 : 1PCS

GRH-15R Pulley Holder BKT Right

- Weight : 0.055kg
- Q'ty/Box : 270pcs

FQ-B Front Haul Ass'y-Quicking Type

- Weight : 3.10kg
- Q'ty/Box : 4pcs

FS-A Front Haul Ass'y-Spring Type

- Weight : 3.40kg
- Q'ty/Box : 4pcs

GRV-15L Ass'y Bearing Pulley Ass'y Left

- GRV-15L : 1pcs, G-15BS : 1pcs
- BRA-32 : 1pcs, GB-02 : 1pcs
- M0625 : 1pcs, M0610 : 1pcs

GRV-15L Pulley Holder BKT Left

- Weight : 0.055kg
- Q'ty/Box : 240pcs

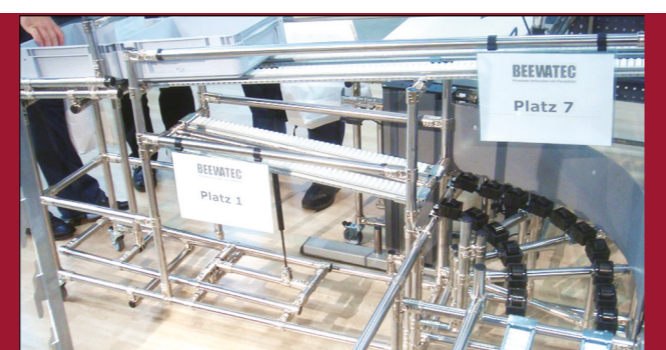

GRV-15R Ass'y Bearing Pulley Ass'y Right

- GRV-15R : 1pcs, G-15BS : 1pcs
- BRA-32 : 1pcs, GB-02 : 1pcs
- M0625 : 1pcs, M0610 : 1pcs

GRV-15R Pulley Holder BKT Right

- Weight : 0.055kg
- Q'ty/Box : 240pcs

Unit : mm

Unit : mm

GS-1014A Sleeve Hanger

- Weight : 0.130kg
- Q'ty/Box : 70pcs

GS-1014B Sleeve Hanger

- Weight : 0.124kg
- Q'ty/Box : 70pcs

HP-30L Holder Panel

- Weight : 0.030kg
- Q'ty/Box : 240pcs

HP-30R Holder Panel

- Weight : 0.022kg
- Q'ty/Box : 400pcs

GS-1014C Sleeve Hanger

- Weight : 0.050kg
- Q'ty/Box : 200pcs

GS-1250A End Snap Rest

- Weight : 0.100kg
- Q'ty/Box : 90pcs

LRA-19 Linear Roller

- Weight : 0.017kg
- Q'ty/Box : 300EA

PHR-28 Hang Roller

- Weight : 0.040kg
- Q'ty/Box : 100pcs

GS-2070C Pipe Plug

* Reference page 52

- Weight : 0.120kg
- Q'ty/Box : 100pcs

GS-2070D Slide Pipe Plug

- Weight : 0.200kg
- Q'ty/Box : 90pcs

MB-15 Monitor Bracket

- Weight : 0.350kg
- Q'ty/Box : 20pcs

PH-A Hanger

- Weight : 0.001kg
- Q'ty/Box : 500pcs

HG-D Hinge Metal

- Weight : 0.052kg
- Q'ty/Box : 100pcs

HK28WA Pipe Rest

- Weight : 0.094kg
- Q'ty/Box : 90pcs

PC-D Pipe Lock Metal

- Weight : 0.157kg
- Q'ty/Box : 50pcs

HK28WB Pipe Rest

- Weight : 0.124kg
- Q'ty/Box : 70pcs

HM28YA Hanger Metal

- Weight : 0.049kg
- Q'ty/Box : 100pcs



Unit : mm

Unit : mm

QS-28 Quick Stopper

- Weight : 0.370kg
- Q'ty/Box : 18pcs

R-A Handle(Round Type)-L400

Design Patent No. 0296008

- Weight : 0.020kg
- Q'ty/Box : 400pcs

TH40PA Tool Holder-Plastic

- Weight : 0.080kg
- Q'ty/Box : 50pcs

TH50PA Tool Holder-Plastic

- Weight : 0.074kg
- Q'ty/Box : 50pcs

RB-2880A Ring Bumper

- Weight : 0.060kg
- Q'ty/Box : 150pcs

RB-3480A Ring Bumper

- Weight : 0.065kg
- Q'ty/Box : 150pcs

TH50YA Tool Holder

- Weight : 0.108kg
- Q'ty/Box : 25pcs

TH60PA Tool Holder-Plastic

- Weight : 0.067kg
- Q'ty/Box : 50pcs

RQ-B Rear Haul Ass'y-Quicking Type

- Weight : 2.10kg
- Q'ty/Box : 4pcs

RQ-C Rear Haul Ass'y-Quicking Type

- Weight : 3.38kg
- Q'ty/Box : 6pcs

TH60PB Tool Holder-Plastic

- Weight : 0.070kg
- Q'ty/Box : 50pcs

TH65YA Tool Holder

- Weight : 0.197kg
- Q'ty/Box : 25pcs

RS-A Rear Haul Ass'y-Spring Type

- Weight : 1.50kg
- Q'ty/Box : 4pcs

TC-28 Tool Cap

- Weight : 0.011kg
- Q'ty/Box : 600pcs

Example for TC-28

Example for Tool Holder





AT SOURCING

ZI Les Malines CE 2701
22 rue des Malines
91090 LISSES

Tél : +33 (0)1 60 86 88 22
Fax : +33 (0)1 60 86 18 22
E-mail : commercial@atsourcing.fr

www.atsourcing.fr

Flexo Line
Février 2023